

GRID SYNCHRONIZING BY USING PLC PROGRAMMING & MATLAB ANALYSIS

1) CH.SHANMUKHA RAO

2) Y.PAVAN KUMAR

3) M.TRIVENI

4) SK.MOHAMMAD SHAROOK

1,2,3,4 :- B TECH 4th year (ANUCET)

ACHARYA NAGARJUNA UNIVERSITY

DEPARTMENT OF ELECTRICAL ENGINEERING

GUIDERS:

1. V.DEGA RAJAJI

ASSISTANT PROFESSOR

DEPARTMENT OF ELECTRICAL

ENGINEERING

ACHARYA NAGARJUNA UNIVERSITY(ANUCET)

2. J. SHIVA NAIK

DEPARTMENT OF ELECTRICAL ENGINEERING

Abstract :- *This project paper is of Thermal power plants controlling by plc ladder logic and synchronizing of different units of a plant . Thermal power plant consist of many important equipment such as boiler ,coal conveyer belt ,ash handling plant ,cooling system etc which are required for the generation of power. These equipment requires continuous inspection and monitoring .this paper outlines the automation of boiler & coal conveyer Automation leads to greater efficiency & reliability .The automation is achieved by using PLC .Analysis of thermal power plant is achieved with help of MATLAB simulation. Different sensors are used for measuring the temperature of boiler ,coal input and turbine action for generation ,these sensors sent required data by continuous monitoring to plc controlling program. In this project we outlining ease of controlling and synchronizing the thermal plant by ladder logic programming using plc for a plant and power analyzing of different unit of plant by using matlab simulation.*

Key words: *Key words: Programmable Logic Controller (PLC), ladder logic diagram ,Power Plant, matlab simulation.*

INTRODUCTION: At initial stages of power generation and its distribution to consumers is very complex and required of continuous attention of men and their role is very crucial .though under the supervision of once the chance of making mistakes in various sector is quite observable.

In order to make the work getting done in perfect and safe environment we need some devices jointly with technology ,where getting job done with ease.

so considering running of a thermal plant under superior supervision such it eliminate the faulty condition in generation

and protects the equipment such that boiler, coal conveyer ,ash handling ,generated steam handling, synchronizing of different units ,by using of Programmable Logic Controller (PLC) with ladder logic diagram. and also analyzing the amount of power that has been being generated ,delivered to load from feeders.

Now a days, it has become a necessity to maintain synchronism because the system is expanding day-by-day and these results in installation of larger machines so in this project we are making synchronism of different units of plant taking NTPS as example with plc.

OBJECTIVE: In order provide continuous supply of power to the load centers and making to find the fault and clearing it in low time so that it can establish continuous supply. mainly securing the quality of supply , by removing the causes of discontinuity by plc ladder logic and establishing the much more sophisticated synchronization . analyzing power being used through matlab simulation.

What is PLC?

PLC is Programmable Logic Controller . plc is a software that acts as a controlling mediator or treated as signaling acting between the field and scada. SCADA (Supervisory Control And Data Acquisition) applications are created as a main tool for performing management.

NEED FOR PLC:

Hardwired panels were very time consuming to wire , debug and change. developed to offer the same functionality as the existing relay logic systems. programmable, reusable, reliable. could with stand harsh conditions. could start in seconds. they had no hard drive , they had battery backup.

PLC Architecture

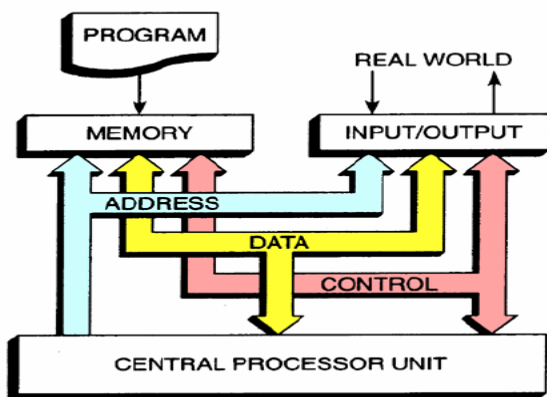

The structure of a PLC is based on the same principles as those employed in computer architecture.

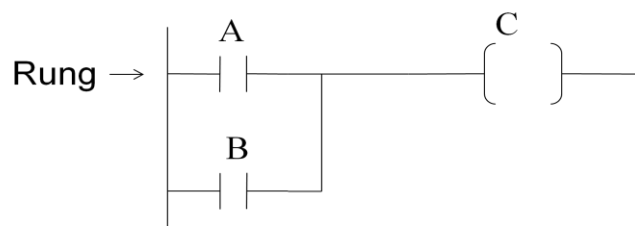

A	B	C
0	0	0
0	1	1
1	0	1
1	1	1

OUTPUT C comes or glows for 1 for A or B.

Discrete Input

A discrete input also referred as digital input is an input that is either ON or OFF are connected to the PLC digital input. In the ON condition it is referred to as logic 1 or a logic high and in the OFF condition it may be referred to as logic 0 or logic low.

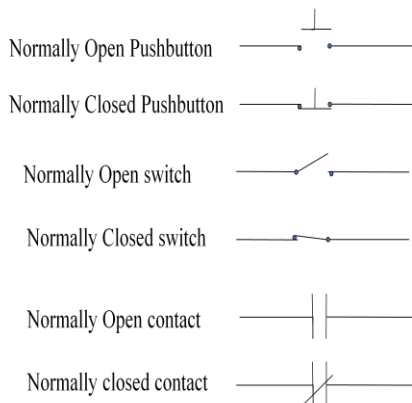

NOT OPERATION :

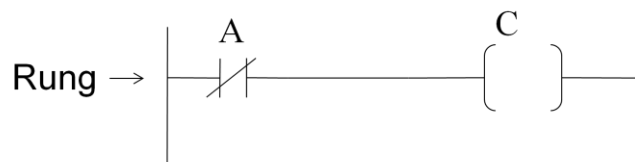

A	C
0	1
1	0

so initially at switch on .

EQUIPMENT THAT ARE NEEDED TO CONTROL OR AUTOMATION :

- 1) coal conveyor
- 2) boiler
- 3) turbine action
- 4) supply to load

1) COAL CONVEYOR AUTOMATION: coal is fed as input to the thermal plants. there will be continuous need of coal for giving temperature to boiler for steam production. the needed coal is conveyed to combustion chamber through conveyor belts . the coal is monitored through IR sensor, proximity sensor, humidity sensor and temperature sensor in the operation of Siemens PLC. **ladder logic for automation coal with time constant to reach the combustion chamber.

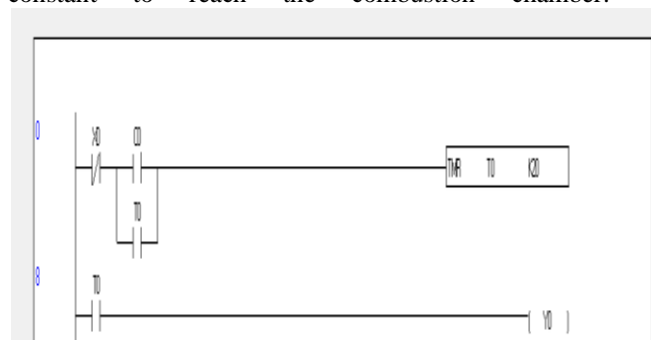

indication for coal input fed

AND OPERATION

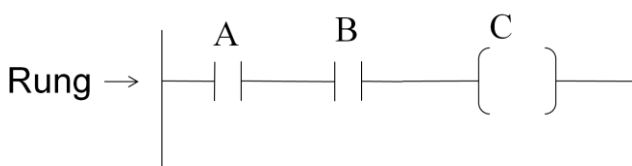

A	B	C
0	0	0
0	1	0
1	0	0
1	1	1

A and B are switches C -OUTPUT
 output comes when A and B are 1

OR OPERATION

2) AUTOMATION OF BOILER: In boiler we need continuous monitoring of water level

and temperature. Here monitoring with sensors is very much advantages because monitoring of temperature continuously manual is dangerous due to high temperatures and not safe for human life. Monitoring of temperature and pressure with using their respective sensors acting as feedback to plc one can easily notice the ongoing changes and sufficient action regarding it.

*ladder logic for automation of boiler with time constant for generation of steam signal of coal is fed time steam generation

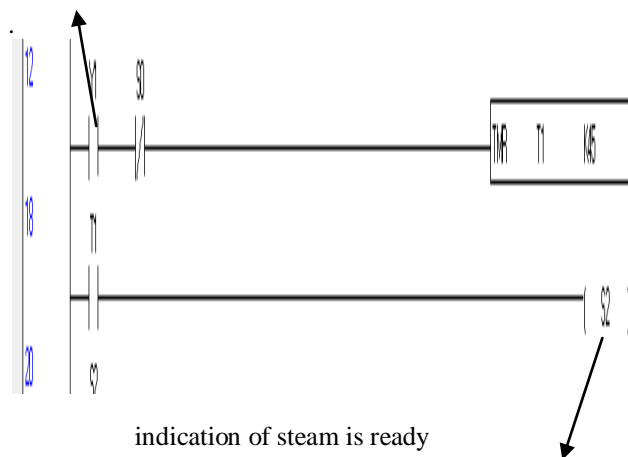

switches one can easily disconnect load from feeder during servicing or at faulty operation. the below logic diagram shows the connection of feeder to load centers.

*ladder logic diagram for connection from feeder to load

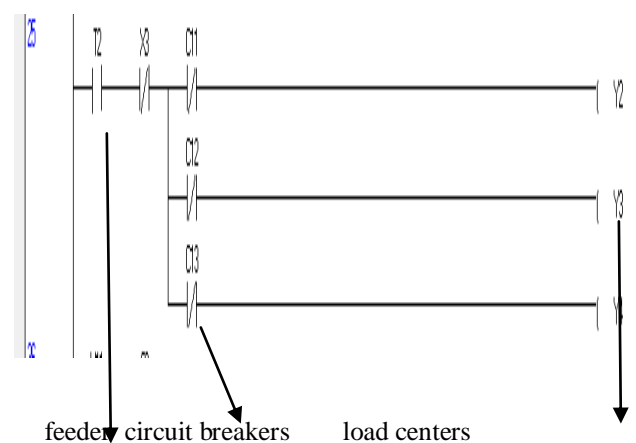

3) AUTOMATION TURBINE WORKING:

As above ladder gives signal output as steam is generated, that steam ready for flowing on to turbine blades .mostly different types of turbines are used depending on steam flow. this turbine shaft is coupled to generator. the generator can supply power at synchronous speed. to get into synchronous speed some time is required for the generator. the below is implementation of ladder logic.

*ladder logic for generation automation with time constant

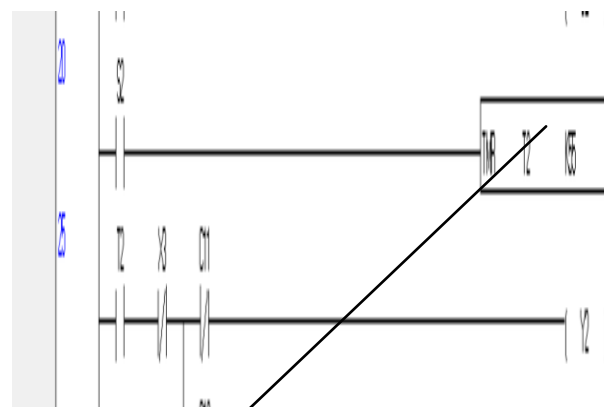

time required for getting into synchronous speed.

4) SUPPLY TO LOAD:

Power that has been generated at synchronous is now supplied to load centers with normally closed switches in ladder logic .through with these normally closed

****TOTAL LADDER LOGIC DIAGRAM OF SINGLE UNIT (NTTPS) USING PLC.**

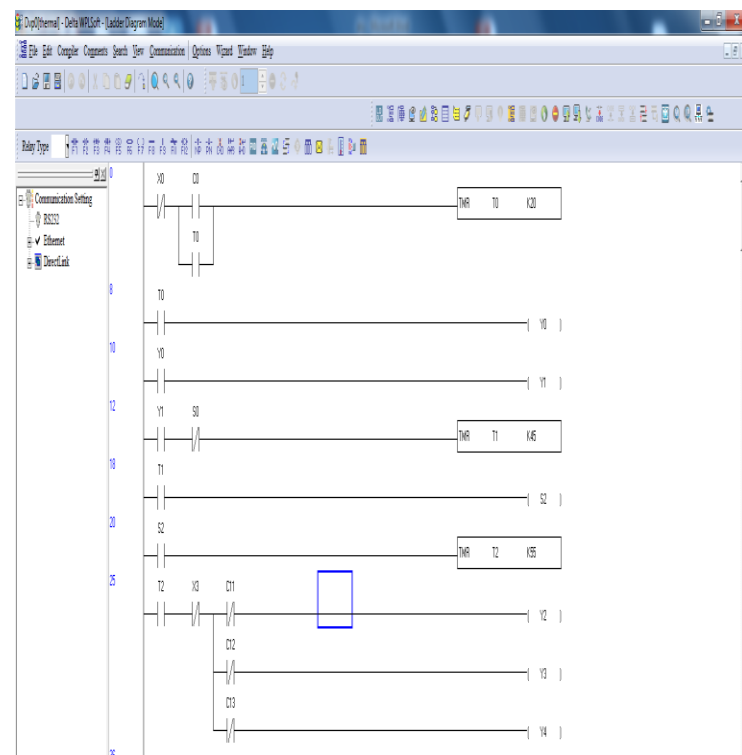

fig 1: complete unit circuit control using plc

from the above figure is implementation of single unit of a thermal power plant. this project is to implement

complete power generated units at NTPPS of Andhra Pradesh. So trying to implement remaining 7units{6*210mw,1*500mw,1*800mw}.Though 800mw is not yet started we had running that unit and synchronized with other units too.

from fig1 we controlled unit by each equipment protection. it has been simple mode of circuit that show the unit operation safely having ease of control towards generation.

***LADDER LOGIC DIAGRAM TOTAL NTPPS UNITS IMPLEMENTATION:**

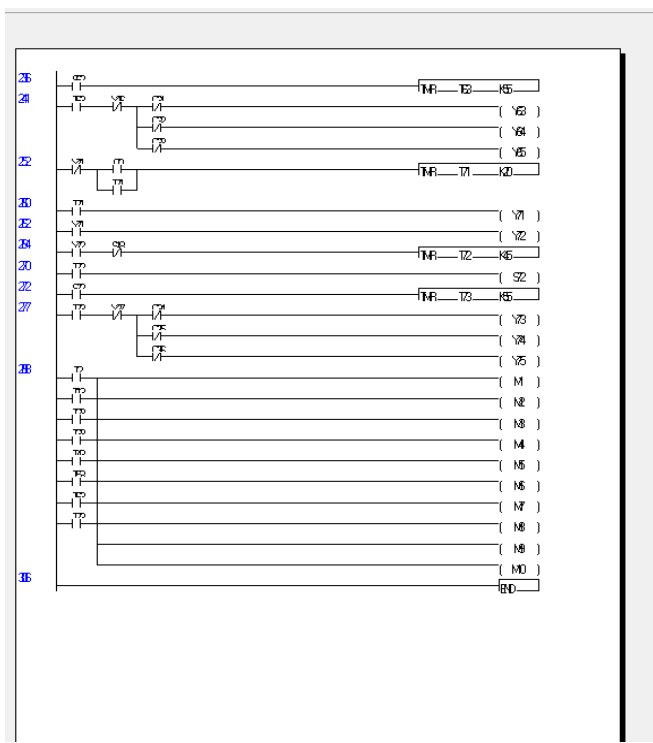
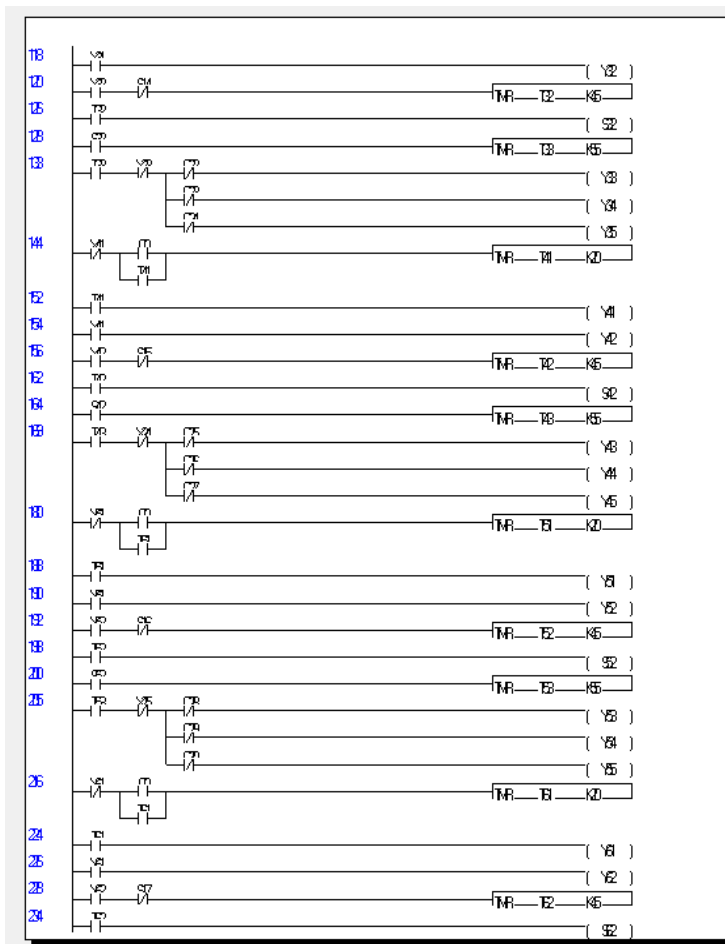
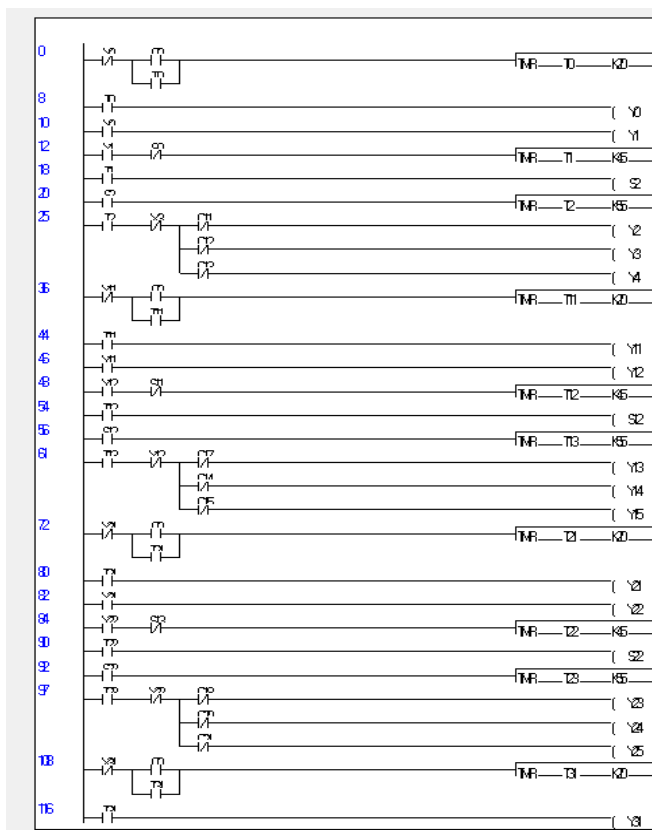

In above ladder logic circuit diagram of 8 units we made controlling at each where equipment for its safe operation and we also synchronized those eight units for good load scheduling.

Below is ladder logic of eight units synchronizing circuit in plc software.

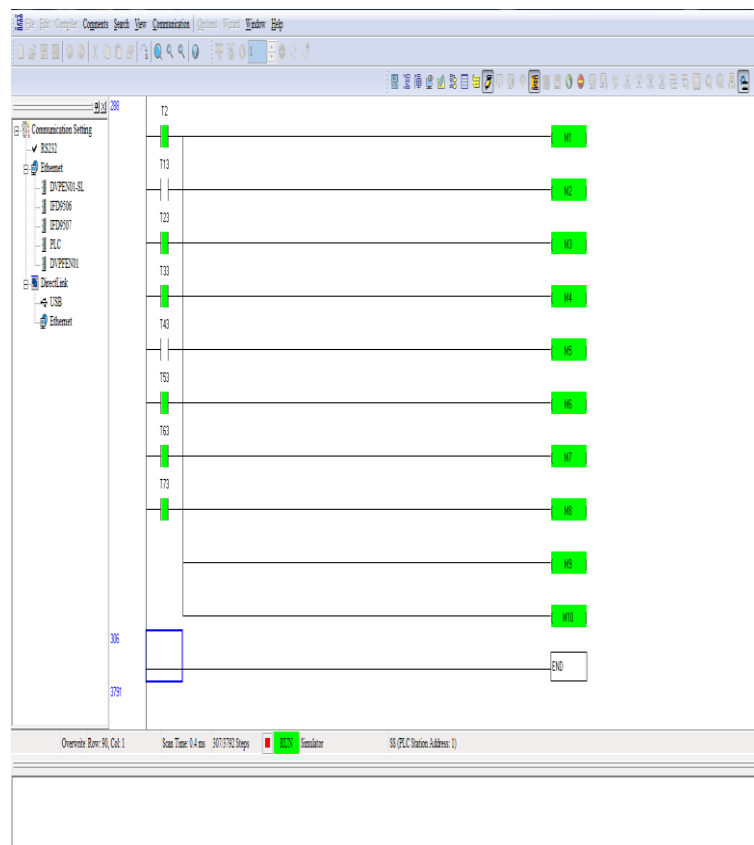
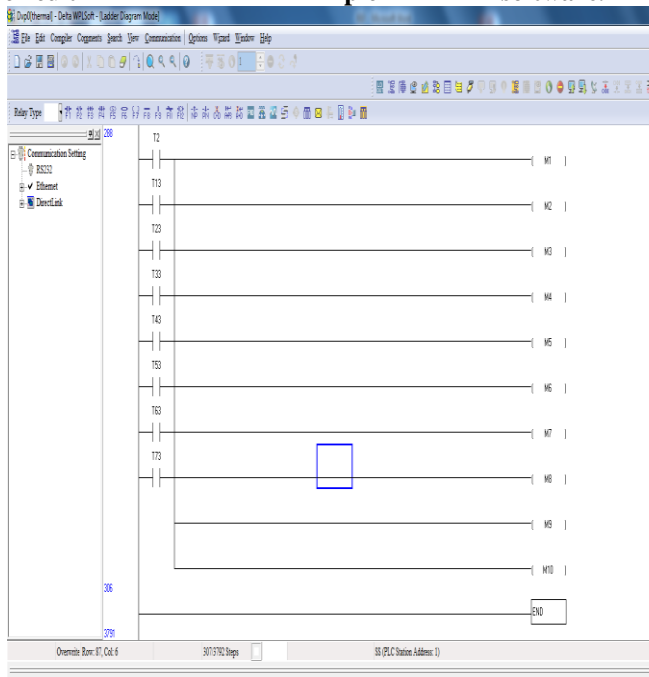

OUTPUT RESULT OF A SINGLE UNIT IN PLC SOFTWARE:

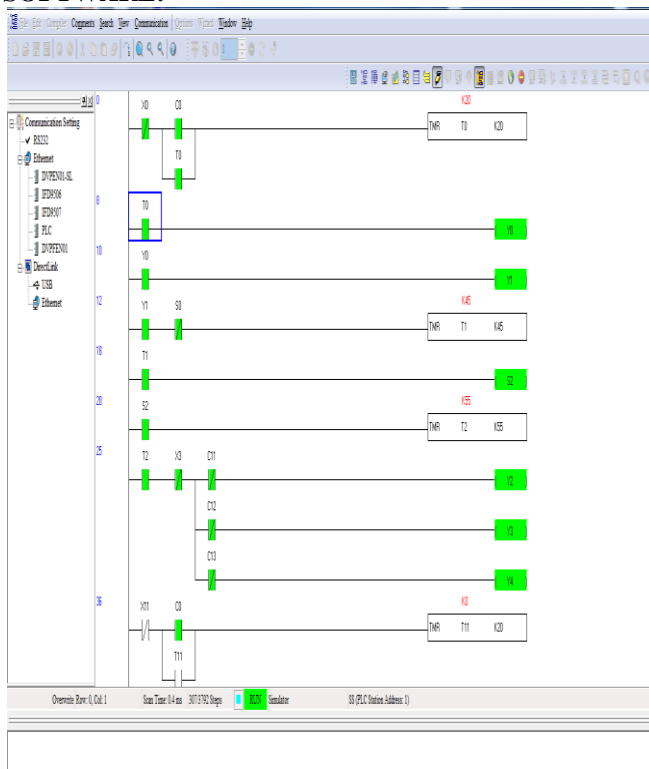

output result of total units synchronizing of NTTPS is as follows:

figure is showing successful load scheduling of units with two of units are in shut down condition generating the power required by the load centers.

MATLAB ANALYSIS:

Above thermal plant has been implemented using plc ladder logic. the plant can be safely operated with each equipment being operated and monitored continuously. Now the part of power being generated in the units and its distribution to load centers is being analysed through math works software. A simple circuit is constructed for 8 units of NTTPS. This circuits shows the basic generation and its distribution to load centers with monitoring of it real and reactive power. And also viewing total load taken.

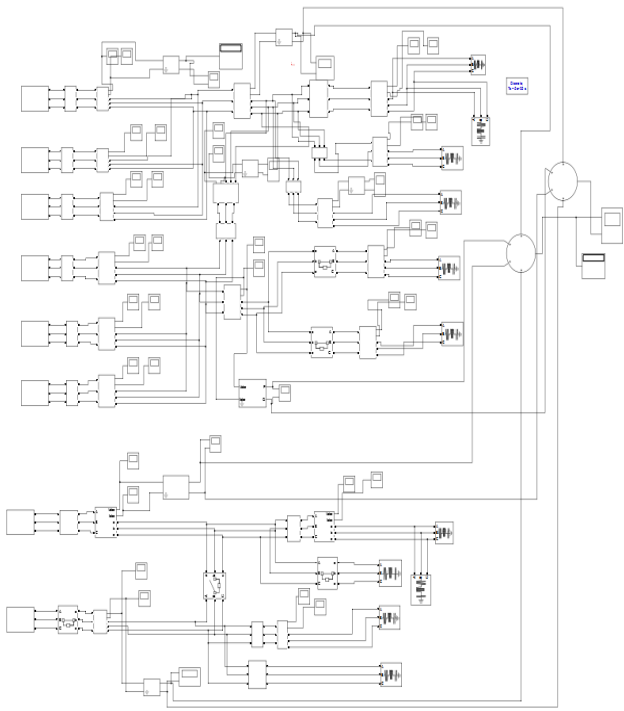
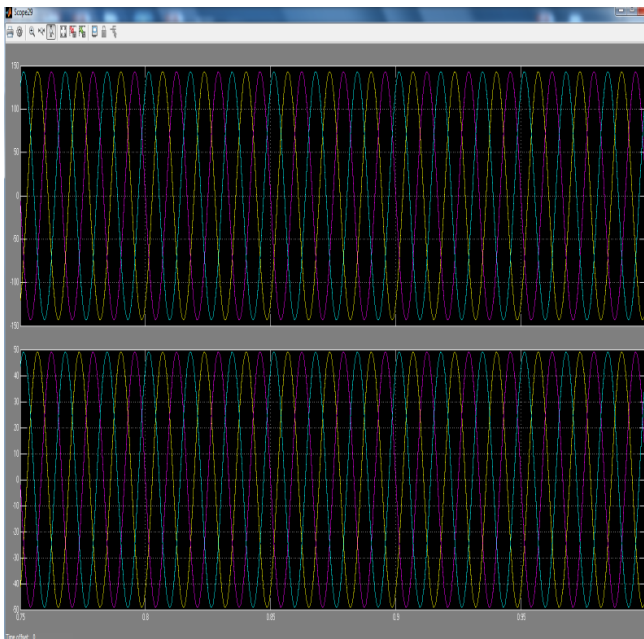

fig2 eight units of Narla Thatharao Thermal Power Station(NTTPS).

from the figure first six units of 210mw have been synchronized sticking to the basic laws of synchronism. remaining two are 500mw and 800 mw they are shown of supplying to industrial purpose. With both of them are synchronised.

RESULTS OF SIMULATION: VOLTAGE and CURRENT of 210 mw unit:



VOLTAGE and CURRENT of 500 mw unit:

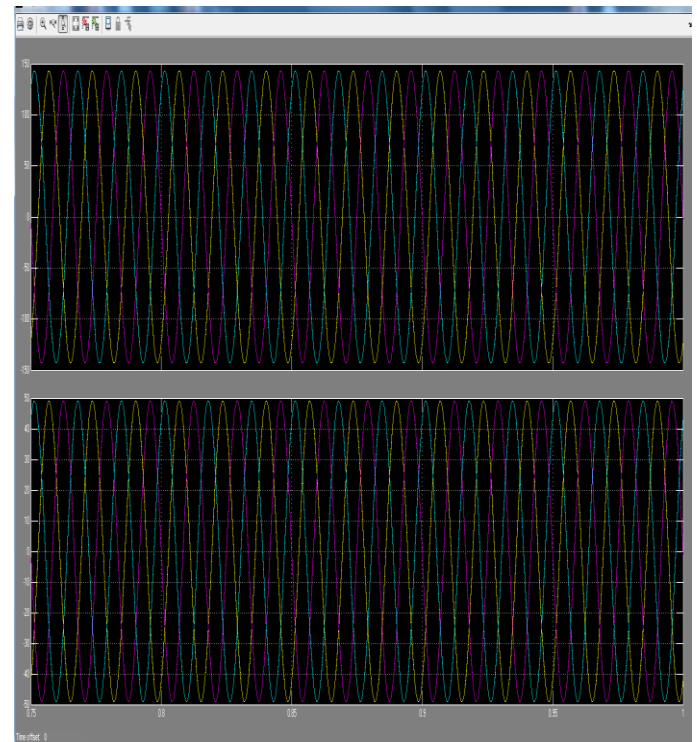

RESULT OF TOTAL REAL AND REACTIVE POWER TAKEN BY LOAD CENTERS:

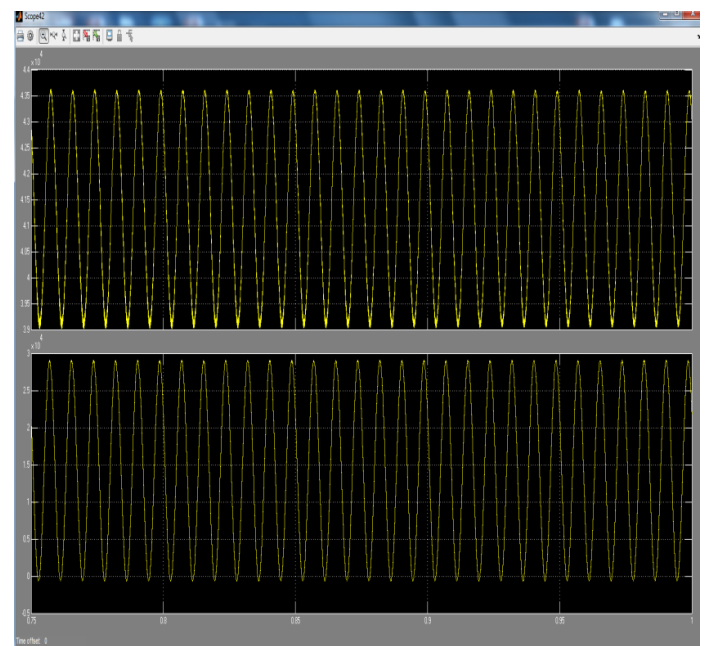

the above simulation results showing the analysis of NTTPS with its load scheduling.

FUTURE SCOPE:

For further advancement of project, the project can be implemented more efficiently by integrating both matlab and plc .With this the controlling is made more reliable And security of the plant has been increased being more advantageous to the plant operator.

The plant operator can control more easily from any place any time with online view by using ETHERNET connection. And with further advanced the plant can be

more efficiently viewed in scada implementation for plant integrating with plc and matlab combination .where one can observe plant working easily and safely.

CONCLUSION:

In this project ,we obtained continuity of power supply with low time of clearing of disturbances, further clearing of fault with ease by programming it plant operation in plc implementation and analyzing through matlab simulation. Finally it all made the operation and control of plant with in safe region of operation by using plc software and math works achieving effective grid synchronization between different units and providing continuity of supply to load centers.

REFERENCES:

1. Petruzella, F. D., *Programmable Logic Controllers*, McGraw Hill, 2005
2. Johnson, C. D., *Process Control Instrumentation Technology*, Prentice Hall, 2006
3. Hassapis, G., “An interactive electronic book approach for teaching computer implementation of industrial control systems ”, IEEE Transaction on Education, Vol. 46, pp. 177 – 184, Feb. 2003
4. Kamen, E. W., Gazarik, M. J., “A course in industrial controls and manufacturing for EE students and other engineering majors”, Proceeding of the 1997 American Control Conference, Vol. 5, pp. 3160 – 3165, June 1997
5. Anderson, J. C., “Design a flexible industrial controls lab module”, 32nd Annual Frontiers in Education, Vol. 1, pp. 17 – 22, Nov 2002
6. Saygin, C., Kahraman, F., “A Web-based programmable logic controller laboratory for manufacturing engineering education”, The International Journal of Advanced Manufacturing Technology, Vol. 24, No. 7-8, pp. 590-298.