

ANALYTICAL AND EXPERIMENTAL BEHAVIOUR OF COLD FORMED STEEL SIGMA AND Z SECTION PURLIN CONNECTIONS

ANBARASAN K , KATHIRVEL M

¹M.E STUDENT STRUCTURAL ENGINEERING & ADHIYAMAAN COLLEGE OF
ENGINEERING, Hosur, a4anbarasan@gmail.com

²ASSISTANT PROFESSOR(CIVIL ENGINEERING) & ADHIYAMAAN COLLEGE OF
ENGINEERING, Hosur, kathirvelnaren@gmail.com

Abstract— Cold formed steel sections are widely used as purlins in industrial buildings. Plain C, Z and sigma sections are most common cold-formed steel purlins in use for roof systems throughout the world. In a pre engineered building of larger bay span two purlins are connected in such a way that it acts as a continuous member. The purlins are connected either by overlapping them or by bolting a short sleeve member that holds and connects the purlins. This paper aims in determining the capacities of bolted overlapped and sleeved connections for z and sigma section having same depth and thickness. The stability, load bearing capacity and failure modes for the four different connections are found by both finite element analysis and experimental test. The finite element analysis is done by ABAQUS/CAE. Results are compared to find which connection type has higher strength and is effective for use in industrial buildings.

Keywords— cold formed steel, Z and sigma purlins, purlin connections, load carrying capacity, ABAQUS/CAE.

INTRODUCTION

In steel construction cold-formed structural members are becoming more popular and have a growing importance. Cold-formed steel exhibits a versatile nature which allows for the forming of almost any section geometry. Cold-formed steel sections are usually thinner than hot-rolled sections and can be subject to different modes of failure and deformation and therefore extensive testing is required to provide a guideline for the design of cold-formed thin-walled structural members.

The main mechanical properties (yield point, tensile strength and ductility) of cold-formed steel sections, particularly at the corners, are considerably different from those of the flat steel sheet, plate, strip or bar before forming. This is because the cold-forming operation increases the yield point and tensile strength, and at the same time decreases the ductility. Light gauge steel purlins are available in different cross sections. Most commonly used sections are C, Z, L and sigma section with or without lip.

BOLTED CONNECTION

The use of bolted connections is one of the most common methods for joining two lapped purlins at the supports. Conventional design practice assumes that the lapped bolted sections do not affect the continuity of the purlins. The strength and stiffness checking of the lapped connection is often performed by treating it as a homogeneous section and calculating the cross-sectional properties of the lapped sections to be double that of a single section.

SCOPE OF THE PROJECT

The scope this study is

- ✓ Single, double and multi-span purlins could be connected in such a way that it acts as a continuous member throughout the building length.
- ✓ Practical difficulty is reduced for erecting continuous purlins for large building length.
- ✓ For a medium to large bay span industrial building, choice for selection of the effective section and connection type in purlins are found.

B .Objectives

- ✓ To analyze the capacity and typical failure modes of two different bolted connections (sleeved and overlapped).
- ✓ To analyze the connections for the two sections by software and experimental results.
- ✓ To compare the load bearing capacity of all the connection types for the same connection length.
- ✓ To illustrate the Failure modes of connections.

SUMMARY OF LITERATURE

The capacity and section behaviour of cold formed steel are studied with help of literatures different points had been taken for the project

The ultimate eccentric loads are sensitive to the yield stress of the steel. The stability of Z-section members (under concentric loads) is sensitive to initial imperfections.

- □Sleeved purlin connections showed non-linear behaviour until failure.
- □A bolted connection in cold formed steel is such that complete rigidity is difficult to obtain.
- □The critical section of the sleeve connection may occur either in the purlin near the outer columns of bolts or in the sleeve near the centre of connection.
- □The corresponding failure modes are the local buckling in purlin webs due to a combined bending and local bearing action, tension fracture failure in the tension flange of sleeve due to the bending.
- □The elastic moment carrying capacity is directly proportional to the cross section of the member.
- □The characteristics of moment resistance and flexural stiffness in the slotted connections are dependent on the ratio of lap length to purlin depth, the ratio of lap length to purlin thickness, the ratio of purlin depth to purlin thickness, and the ratio of lap length to span.

PURLIN SECTIONS AND CONNECTIONS

The main process of cold formed steel structural elements involves forming steel sections in cold state sheets at uniform thickness. The thickness of steel member ranges from 0.4 mm to 6.4mm. The cold forming operation increases the yield point and ultimate strength of the steel sections.

A. SECTION PROPERTIES

Commonly used cold formed sections for purlin are C, Z, L and sigma section. In this study two purlin sections are chosen Z and sigma section.

B. Z SECTION

A 'Z' section is a point symmetrical about a point (centroid). 'Z' sections having equal flanges are a point symmetric section. 'Z' section will buckle laterally at a lower stress than 'I' beam or channel section. 'Z' section is taken code IS: 811-1987. Depth of section is taken as 200mm and thickness of 2mm. properties of the section, h = 200 mm

- b = 60 mm
- c = 20 mm
- t = 2 mm
- $I_{XX} = 400 \text{ cm}^4$
- $I_{YY} = 48.5 \text{ cm}^4$
- $Z_{XX} = 8.22 \text{ cm}^3$
- $Z_{YY} = 38.8 \text{ cm}^3$

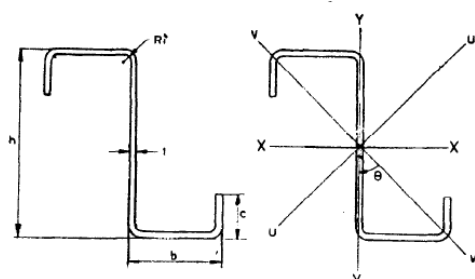

FIGURE 1 . Z SECTION AS PER IS:811-1987

C. SIGMA SECTION

Cold-formed steel sigma purlins normally possess advantageous structural features such as an enhanced web buckling resistance and a location of shear centre closer to the web. In comparison with their counterparts such as Z and C sections, sigma sections have an improved web buckling resistance due to the presence of web stiffeners. Lipped sigma section is taken for this study with respect to eurocode EN 1993-1-3-2006 with depth 200 mm and of thickness 2 mm

properties of the section ,

$h = 200 \text{ mm}$

$b = 62.5 \text{ mm}$

$c = 20 \text{ mm}$

$t = 2 \text{ mm}$

$I_{XX} = 447.74 \text{ cm}^4$

$I_{YY} = 30.68 \text{ cm}^4$ and outer web = 45 mm

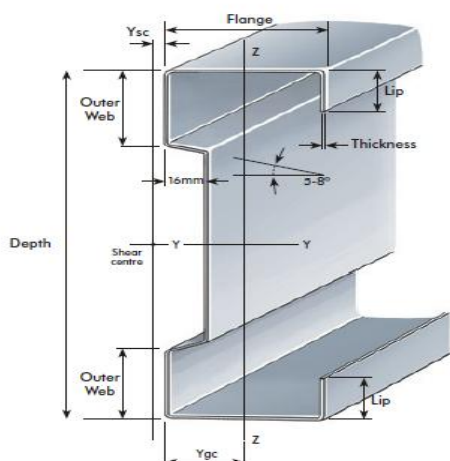

FIGURE 2. SIGMA SECTION BASED ON EUROCODE

D. SELECTION OF CONNECTION

Connections in steel are normally made either by bolting or welding. Bolting is common in field connections, since it is simple and economical to make. However, welded connections, which are easier to make and are more efficient, are usually resorted to in shop fabrications Purlins can be connected either by overlapping or connecting a small sleeve member and are bolted together. The size of bolt to be used here is 6mm diameter .

E. OVERLAPPED CONNECTION

In this type of connection purlins are provided with an extra length called overlapping length where it is lapped with adjacent purlin and are bolted together.. Lap length is distance between centre to centre of the edge bolts. Lap length for a purlin connection depends on parameters like span of the beam, depth of the purlin section. The failure of an overlapped connection is directly proportional to the length ratio, which is the ratio of the lap length to beam span. In practice the normal lap length adopted is 12.5% of the bay span. In this project the span of the beam may be assumed as 4 meters and the lap length is 0.5meters.

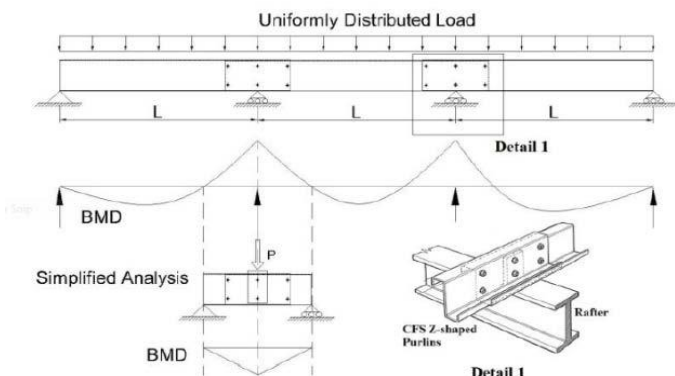

FIGURE 3. SIMPLIFIED ANALYSIS FOR LAPPED CONNECTION

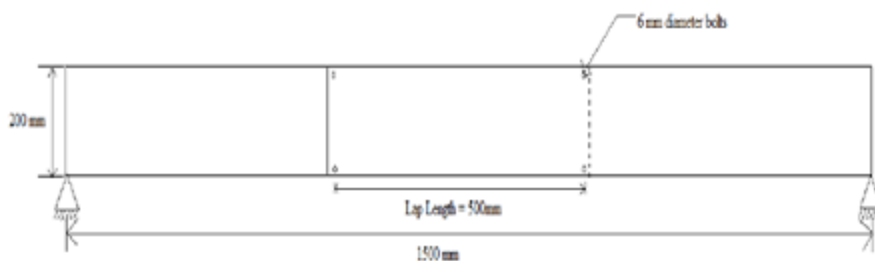

FIGURE 4. SCHEMATIC REPRESENTATION OF LAPPED CONNECTION

F. SLEEVED CONNECTIONS

In this type of connection a short cold-formed steel member similar to the purlin that holds and connects both purlins. The sleeve length adopted here is 0.5m as that for lapped connection for better analysis and comparison.

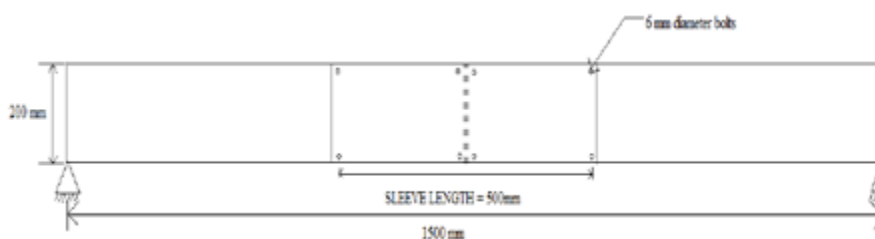

FIGURE 5. SCHEMATIC REPRESENTATION OF SLEEVED CONNECTION

G. SLEEVED CASES

- Type 1 - Z section overlapped connection.
- Type 2 - Z section sleeved connection.
- Type 3 - Sigma section overlapped
- Type 4 - Sigma section sleeved connection

FINITE ELEMENT ANALYSIS

The finite element analysis for the four connection cases is done by ABAQUS/CAE software. The first step in the model tree of abaqus/CAE is creating a model for which boundary conditions and loads are assigned for further analysis . The total length of the specimen is 1.5m and depth of both Z and sigma section is 200mm.

As per the simplified analysis mentioned in figure 3.3 a concentrated load is applied at the midpoint of the specimen with boundary conditions .the models are the meshed and analysis is done. From the analysis the peak load and deflection at the mid span are obtained.

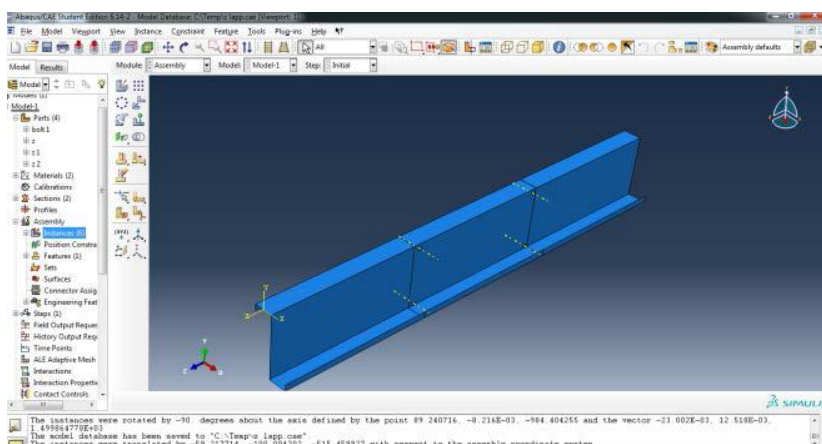

FIGURE 6. MODEL ASSEMBLY FOR Z SECTION OVERLAPPED CONNECTION.

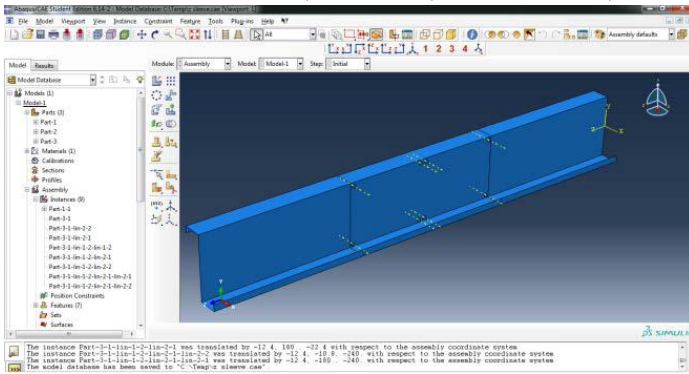

FIGURE 7. MODEL ASSEMBLY FOR Z SECTION SLEEVED CONNECTION

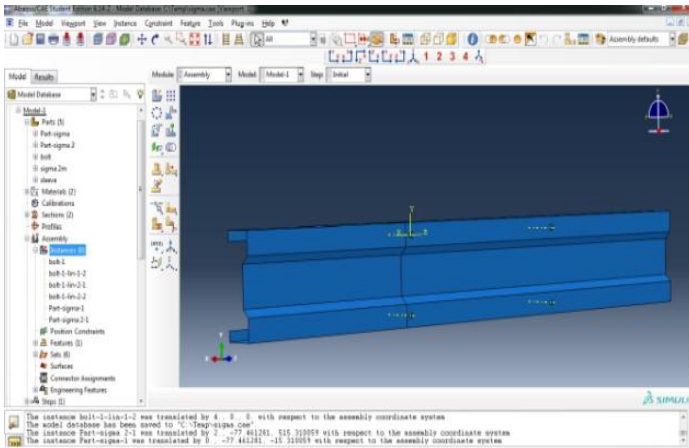

FIGURE 8. MODEL ASSEMBLY FOR SIGMA SECTION LAPPED CONNECTION

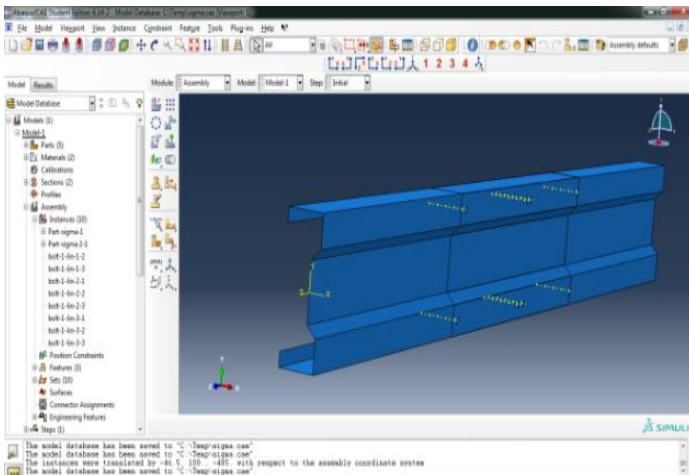

FIGURE 9. MODEL ASSEMBLY FOR SIGMA SECTION SLEEVED CONNECTION

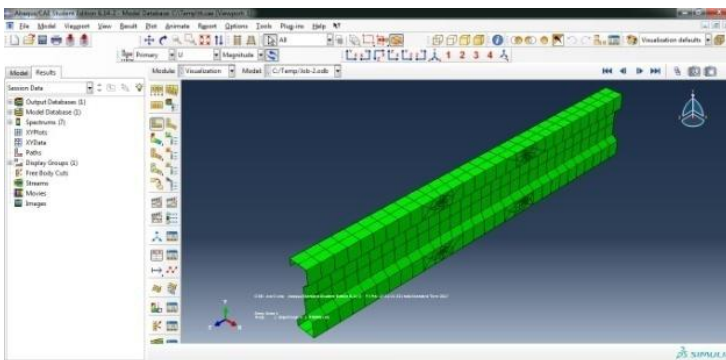

FIGURE 10. MESHING OF MODEL (TYPE 3)

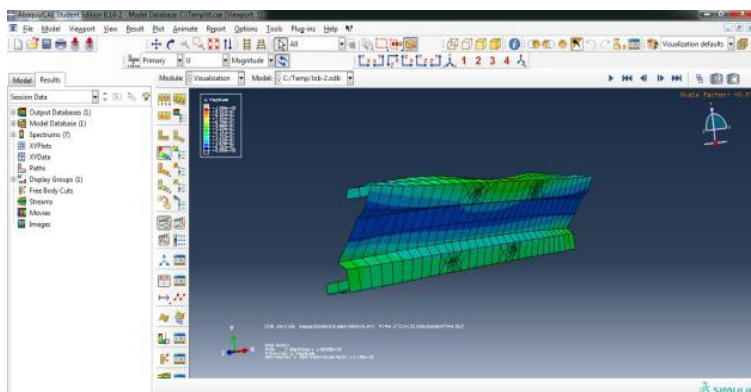

FIGURE 11. STRESS DISTRIBUTION (TYPE 1)

TABLE 1. ULTIMATE LOAD & DEFLECTION FROM ANALYSIS

TYPE	CONNECTION	PEAK LOAD(KN)	DEFLECTION AT MIDSPAN (mm)
1	Z section overlapped	17.89	7.25
2	Z section sleeved	15.21	4.10
3	Sigma overlapped	24.11	9.95
4	Sigma sleeved	19.75	4.38

EXPERIMENTAL ANALYSIS

A. LOAD AND DEFLECTION

The purlin assembly was supported at span of 1.5 m. A point load was applied at the midpoint by loading jack. Three LVDT's are placed at two quarter and mid-span points to measure the vertical deflection. The loading was applied at 2 KN increment and corresponding deflection at points 1, 2 and 3 are noted. The same loading was repeated for all the four specimens. The peak load and deflections at peak load are obtained for the four cases.

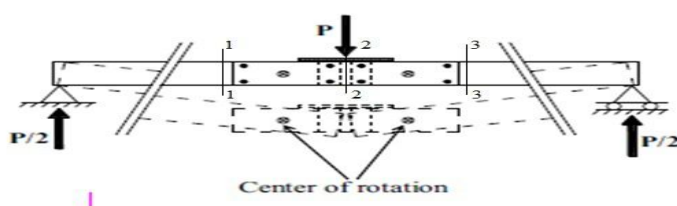

FIGURE 12 CENTRE OF ROTATION FOR SLEEVED CONNECTION



FIGURE 13. EXPERIMENTAL SET UP OF TYPE 2 CONNECTION



FIGURE 14. EXPERIMENTAL SETUP OF TYPE 3 CONNECTION

The deflection at the quarter spans in z section sleeved and sigma section sleeved connection are negative due to rotation of the purlin member about centre of rotation.

TABLE 2 DEFLECTION AT TWO QUARTER SPANS AND MIDSPAN AT PEAK LOAD

CONNECTION TYPE	PEAK LOAD (KN)	DEFLECTION AT MIDSPAN (mm)		
		At 1-1	At 2-2	AT 3-3
Z section overlapped	18.5	4.15	7.90	4.95
Z section sleeved	14.5	-3.13	3.56	-3.08
Sigma section overlapped	23.5	7.82	10.71	6.92
Sigma section sleeved	20.5	-3.08	4.10	-3.09

B. BENDING MOMENT SHEAR FORCE

The strength of continuous purlins is given by the interaction of shear forces and bending moment. Alomir H. Favero Neto presented the equations to calculate the bending moment and shear force on the purlins and sleeve and on the purlins, respectively for sleeved and overlapped connections.

It is necessary to note that the diagrams for overlapped connections do not take into account the contribution of the central bolts due to their much smaller radius of action, but if geometry imposes, one needs to modify the above diagrams accordingly.

TABLE 3: SHEAR FORCE AT PEAK LOAD FOR ALL TYPES.

TYPE	PEAK LOAD (KN)	FORCE IN BOLT (F_b)	V_1 (KN)	V_2 (KN)	V_3 (KN)
1	18.5	12.02	9.25	-13.5	22.8
2	14.5	9.42	7.25	-8.4	15.6
3	23.5	15.92	12.2	-17.9	30.2
4	20.5	13.32	10.2	-11.9	22.1

TABLE 4: BENDING MOMENTS AT PEAK LOAD

TYPE	FORCE IN BOLT (F_b)	M_1 (KNm)	M_2 (KNm)	M_3 (KNm)	M_4 (KNm)	M_5 (KNm)
1	12.02	14.45	13.8	3.46	0.60	-
2	9.42	3.69	2.86	0.83	4.6	5.4
3	15.92	6.24	5.44	4.59	0.81	-
4	13.32	5.22	4.04	1.18	6.5	7.6

C. FAILURE MODES

The connections Z section overlapped and sleeved (type 1 & type 2) fails due to distortional buckling. Whereas the sigma section overlapped and sleeved connection (type 3 & type 4) showed flexure-torsional buckling. Local buckling of purlin flanges and sleeve member occurred



FIGURE 14 FLEXURE-TORSIONAL BUCKLING FAILURE (TYPE 3)



FIGURE 15 DISTORTIONAL BUCKLING

CONCLUSION

The analytical and experimental analysis indicate that

- Lapped connection of both Z and sigma section shows maximum capacity than sleeved connection.
- The type 3 connection (sigma section lapped) shows higher capacity of than other types from both analytical and experimental results.
- Z section overlapped and sleeved connections failed due to distortional buckling and sigma section overlapped and sleeved connection due to flexure-torsional buckling.
- When comparing a sleeved and overlapped connection, lapped connection is efficient than sleeved one.
- In practical application the sleeve length could be provided more than 13 % of the span length to attain same strength as that of lapped connection.

REFERENCES

“PURLIN AND GRITS DESIGN GUIDE” by Stratco steel in accordance with limit state design principles and comply with the Australian/ New Zealand Standard AS/NZS 4600:2005 Cold-formed.

Building Design Using Cold Formed Steel Section Mr. Roshan S Satpute, Dr. Valsson Varghese M.Tech (Structural Engineering) Karmaveer Dadasaheb Kannamwar College of Engineering.

BSI Design of steel structures—cold formed structures. BS EN 1993-1-3:2006

Rene W. Purnadi, John L. Tassoulas, Dimos Polyzoi (1990), “ A study of cold-formed z-section steel members under axial loading”, (October 23, 1990). International Specialty Conference on Cold- Formed Steel Structures. Paper 7.

D. B. Moore (1990), “ Moment-rotation characteristics of purlin connections” (October 23, 1990). International Specialty Conference on Cold- Formed Steel Structures. Paper 2.

F. Zadanfarrokh , E.R.Bryan (1992), “Testing and design of bolted connections in cold formed steel sections” International Specialty Conference on Cold-Formed Steel Structures. Paper 3.

Markku Laine, Pentti Makelainen (1994), “ Study on the load-bearing capacity of cold-formed sigma purlins” (October 18, 1994). International Specialty Conference on Cold-Formed Steel Structures. Paper 2.

Roge A. LaBoube, Wei-wen Yu, Michael L. Jones (1998), “Spacing of Connections in Compression Flanges of Built-up Cold-formed Steel Beams” (October 15, 1998). *International Specialty Conference on Cold-Formed Steel Structures*. Paper 4.

Jian Yang, Qiang Liu (2011), “ Sleeve connections of cold-formed steel sigma purlins” *Int. Journal of Applied Sciences and Engineering Research*, Vol. 1, Issue 3, 2012.