

POWER-ELECTRONICS BASED EFFICIENT ENERGY MANAGEMENT SYSTEM WITH FUZZY LOGIC CONTROLLER

¹D. SUBBARAYUDU, ²SHAIK HUSSAIN VALI

¹M.Tech, JNTUA College of engineering, pulivendula, A.P, India. Space of interest electric power System.

²Assistant Professor, JNTUA College of engineering, pulivendula, A.P, India. Space of interest electric power System.

ABSTRACT: *This paper exhibits about utility of a power electronics based energy management system (EMS), it incorporates storage devices and a rigorously managed single-stage voltage source inverter, that may be controlled as a current source or voltage source contingent upon the standing of the ac grid and also the client's inclination. The EMS ensures fundamental burdens are burning once ac system flops; in that condition, The VSI is restricted as a voltage source. This likewise finishes peak management by providing supply from storage device to the neighborhood masses whereas they're controlled by the ac grid if the lots get large. Power price reserve funds achieved by high shavings are calculated. The management engineering and principle put in this paper are talked regarding thoroughly.*

INDEX: *Crest power management, Fuzzy controller, Energy management system, energy storage, voltage source inverter(VSI).*

INTRODUCTION

Saving and potency of electrical energy have clad to be high desires all round the globe, rested by the city convention and different compression must reduce non-renewable energy source utilization.

This paper exhibits, a power electronics based energy management system is presented fulfill high power management during a solitary stage management system whereas making certain persistent support of basic masses within the meanwhile. Pinnacle management, otherwise known as high shaving, may be a technique accustomed diminish the power accuses for shoppers of your time of utilization contracts and also the people give for the request electricity bill. The power system ought not to be a small grid, implying that disseminated age doesn't ought to be a bit of the Power system. The management system projected during this paper incorporates energy reposition as batteries keeping in mind the top goal to end 3 principle objectives:

1) Build electrical power accessible to basic masses systematically with or while not basic network profit accessible, 2) Diminish high power utilization to bring down power expenses, and 3) Store energy delivered by amid the time within which power from the grid is slightest pricey. As these days specialists have utilized power converters to execute management administration or EMS for ac and dc micro grids.

The results in the paper incorporate Power- quality arrangements, reliability problems, sustainable age interface, and advanced third level micro grid management with load and age estimate. Most productions have targeting the energy administration of micro grids as well as a number of disseminated assets (DR) whereas during this paper, we have a tendency to target handling an influence system that includes storage device reposition.

This paper, whereas following on an identical line of analysis, presents approaching of consistent support of basic burdens with crest management shaving. It likewise incorporates a basic money examination to exhibit the upsides of the top management shaving technique. Moreover, easier management systems and sudden topologies compared to those proclaimed in through. Another ingenious part of EMS exhibited during the paper is that the utilization of three-leg incorporated unit to meet each one of the specified undertakings as well as battery charging, high shavings, adaptation to non-critical failure.

PROPOSED SYSTEM EMS DESIGN AND PRACTICALITY

The system exhibited during this paper incorporates storage devices and a three-legged management unit maintained with the space Programmed entry cluster.

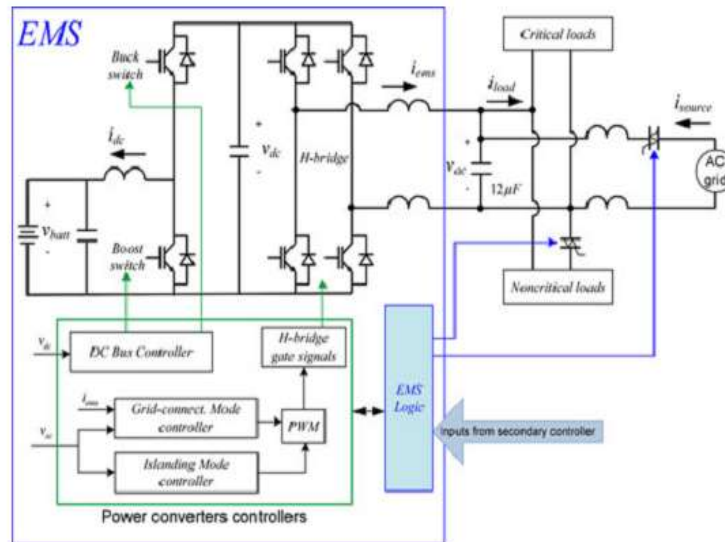

Fig.1. Design of EMS.

A 3-stage insulated gate bipolar transistor management unit is management accomplish Buck and carry control team of one leg of the unit and single stage voltage source behavior in cascade-connect inverter from opposite 2 legs of the unit. The cascade-connect electrical converter, hence, framed is related to a yield LC channel to deliver the curved voltage for the ac masses. It consists of two potential detectors to screen the potentials v_{dc} and V_{ac} and two current detectors for ems and load currents. Electric battery bank is related to the buck– support leg to attain two-way supply stream in/out the battery. This accumulator includes six 12-V cells in arrangement, shaping 72-V battery bank.

The EMS utility is shown during this paper by searching approval with a pursuit center model. The incidental to things are examined: 1) high shaving by sound the energy reposition system amid more power request; 2) Islanding or stay solitary technique of operation once the first ac grid isn't to any extent further accessible; 3) Charging mode of battery. For fulfilling these objectives, EMS is exceptionally valuable in grid associated systems, wherever there's some extent of confinement on client's energy utilization. This farthest purpose maybe upheld by tripping device (CB) controlled by power unit. During this phenomenon, EMS holds the source current to a lower place a group edge systematically by stack administration and shedding, at that time the shopper will work stacks past the steady state management cutoff points of the ac system for temporary circumstances while not agonizing over the controller intrusive on profit.

The EMS will likewise valuable once the shopper includes time of utilization (TOU) power agreement with organizations and remunerate numerous prices for management sent at numerous circumstances on that time. In that condition EMS will contend with the energy place away and energy attracted from grid to minimize utilization once the rates of power are more. This method is thought as load smooth out energy time move, accomplishes power price decrease for the shopper. On a self-sustaining micro grid, wherever a minimum of one generators are utilized to manage distinctive burdens, the EMS permits derating the storage devices by dominant the top current taken from the battery. This will likewise guarantee energy to basic burdens is preserved amid blame by overseeing energy reposition. Accidental islanding is unwanted and might be a welfare issue amid repairs occasions.

The EMS management calculation was created with the incidental to objectives, recorded here organized by need:

- 1) Management should be accessible to the fundamental masses consistently;
- 2) diminish the top management consumed by the small grid by utilizing battery management;
- 3) To amplify condition for battery charge;
- 4) Build management accessible to non-critical burdens.

CONTROL STRATEGY FOR EMS MANAGEMENT

It is important to acknowledge the distinctive levels of management for EMS. The essential management system incorporates convertor unit that manufacture the reference signals for voltage references. The optional management system may be a larger quantity controller, which may incorporate the shopper information and settles on decisions in sight of parts, as an example, battery condition of charge and lifelong, price of power, stack need, then forth. This analysis concentrates on the essential management system. The essential parts of the main control circuit are incorporated and analyzed in delicate parts.

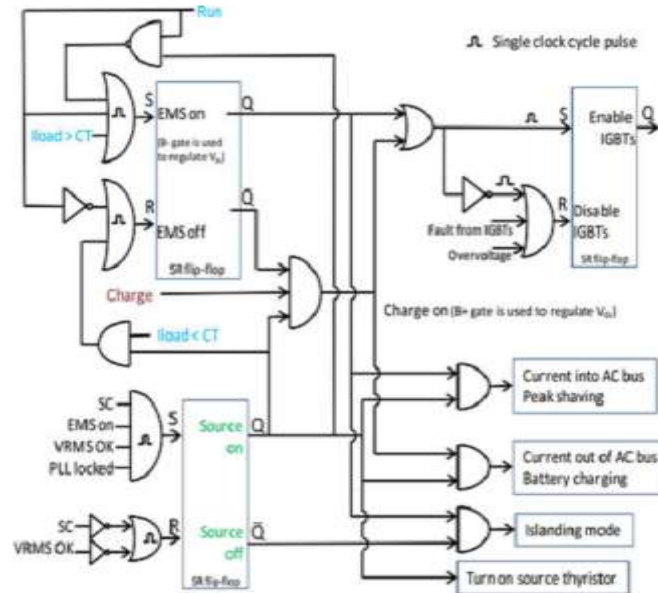

Fig.2. Controller circuit inside EMS.

Fig.2 Demonstrates the EMS essential controller principle flow sheet. The administrator of the auxiliary input controllers Four clear coherent summons; To Run, Charge, Source connect and Current Threshold. The current threshold is that heap level of current once the energy management system can start high shavings. On the off likelihood that Run is low, at that time the EMS will nothing. At the purpose once Run is maximum, the system can work within way of islanding. within the event that SC is likewise high, at that time the EMS can associate holiday to the ac supply if the ac supply voltage is over 100 V rms. within the event that the heap current surpasses the top shaving limit (CT), at that time the EMS can stick with it injecting gift, typically the EMS can kill within the wake of interfacing with the ac supply. within the event that charge is about high, at that time the EMS can charge the batteries once the ac supply is on the market and high shavings is not requested.

EMS management in islanding mode

Stay solitary mode happens once the ac grid is de-energized. The management calculation for that technique of operation is appeared Fig. 3.

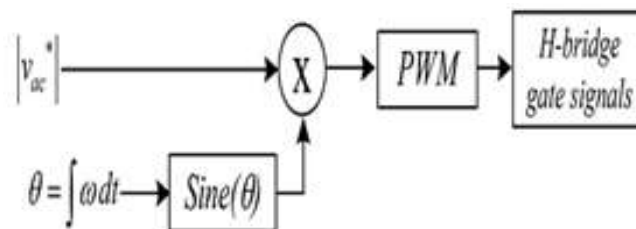

Fig.3. Management algorithmic rule for islanding mode.

The adequacy of the ac voltage, v_{ac} , is about to a 110 V rms. The electrical purpose, θ , is characterized by coordinating the rakish repetition that is about to 60cps. Unipolar heartbeat breadth regulation is used to run H-connect IGBTs.

II. EMS management for current infusion

Energy management system will provide a few profitable grid bolster capacities once the EMS is related to a dynamic ac grid. These ways of behavior work the system as a current source. Current infusion ways of operation are appeared in Fig. 4.

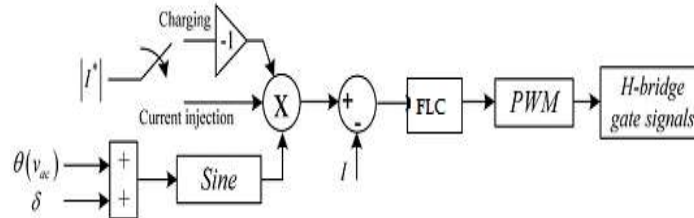

Fig.4.Management algorithmic rule to current infusion.

The dc bus that powers the H-connect and also the buck– facilitate switches is controlled as appeared in Fig. 5. Simply one IGBT is adjusted at any given time thus once the buck or carry convertor is in broken conductivity mode, the current doesn't cross zero. This enhances the proficiency contrasted with driving each switches perpetually. At no matter purpose battery charging mode is picked, current is infused into the dc bus by the H-connect and also the dc-bus controller works in buck form to convey the energy to the battery bank. At the purpose once the EMS is in current infusion mode, the Power sent to the ac bus is drawn from the dc bus and also the dc-bus management works in support mode to carry the dc bus up utilizing battery control.

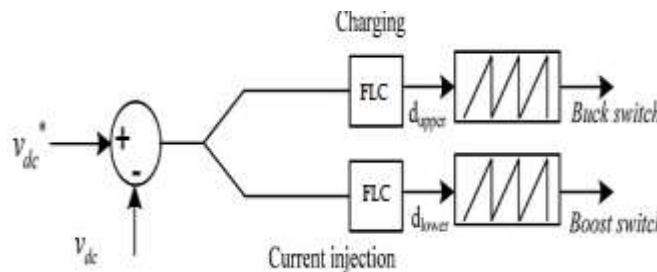

Fig.5. DC bus management algorithmic rule.

FUZZY LOGIC CONTROLLER

In Fuzzy logic controller, essential management activity is set by a briefing of semantics standards.

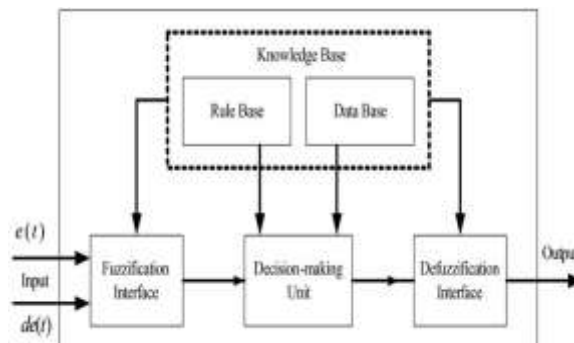

Fig.6.Fuzzy logic controller

The fuzzy logic controller contains 3 sections: fuzzification, obstruction motor and defuzzification.

The control is delineated as;

1. seven downy sets for every information and yield.
2. Triangular participation capacities for ease.
3. Fuzzification utilizing nonstop universe of speak.

4. Suggestion utilizing Mandeni’s, minimum administrator.

5. Defuzzification utilizing the peak strategy.

Table 1: Fuzzy rules

Change in error	Error						
	NB	NM	NS	Z	PS	PM	PB
NB	PB	PB	PB	PM	PM	PS	Z
NM	PB	PB	PM	PM	PS	Z	Z
NS	PB	PM	PS	PS	Z	NM	NB
Z	PB	PM	PS	Z	NS	NM	NB
PS	PM	PS	Z	NS	NM	NB	NB
PM	PS	Z	NS	NM	NM	NB	NB
PB	Z	NS	NM	NM	NB	NB	NB

Fuzzification: Associateship perform values are allotted to the semantic inconstants, victimization seven subsets. negative big(NB),negative medium (NM),negative small (NS),zero(ZE),positive small (PS),positive medium (PM),positive big (PB). The Partition of downy subsets and also the state of participation CE (k), E(k) work change the watch out of business to correct system. the estimation data} blunder and alter in mistake are standardized by associate degree information scaling issue. In this system info the knowledge the data} scaling issue has been made public to such associate degree extent that information esteems are between -1 & $+1$. The triangular state of the enrollment capability of this arrange presumes that for a selected E(k) contribution there's simply one predominant downy set.

Inference Method: a number of structure ways, as an example, Max– Min and Max-Dot are projected within the writing. During this paper Min strategy is used. The yield enrollment capability of every manage is given by the bottom administrator and most extreme administrator.

De-fuzzification: The foremost half needs a non-fluffy estimation of management, a de-fuzzification organizes is needed. To method the yield of the fuzzy logic controller height strategy is used and also the fuzzy logic controller yield alters the management yield. Further, the yield of fuzzy logic controller controls the switch within the electrical converter. In UPQC, the dynamic power, receptive power, terminal voltage of the road and electrical device voltage are needed to be preserved. thus on management these parameters, they're detected and contrasted and also the reference esteems. To accomplish this, the enrollment parts of FC are: mistake, modification in blunder and yield

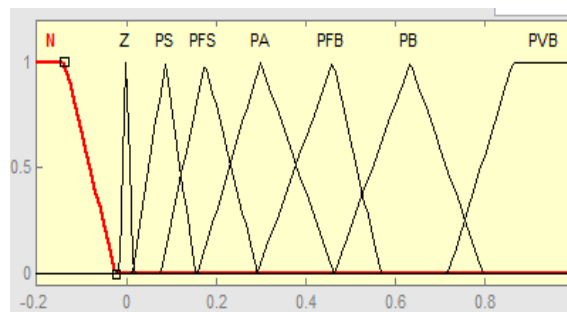

Fig.7. Input error as membership function

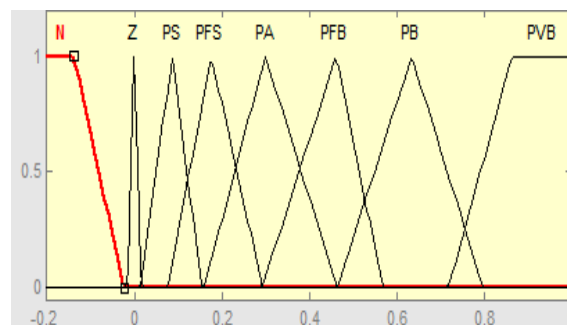

Fig.8. Modification as error membership function

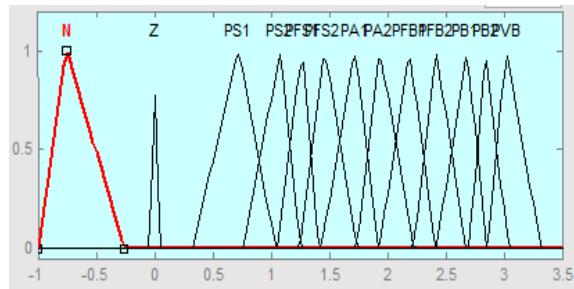

Fig.9 Output inconstant membership functions

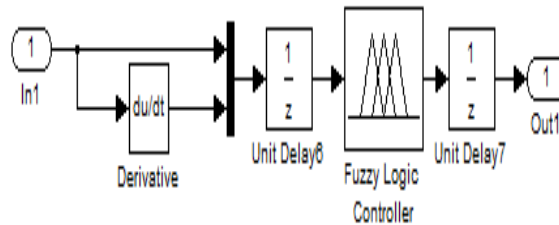

Fig 10.fuzzy logic controller in simulation

SIMULATION RESULTS

The circuit appeared in Fig.11 was worked inside the simulation facility to show the EMS usefulness. The ac voltage is $v_{ac} = 120V_{rms}$, the battery p.c. Voltage is $v_{batt} = 72V_{dc}$ and it's miles helped to make the dc-bus voltage $v_{dc} = 200V$ for the H-bridge inverter. The EMS yield get out appeared in Fig. 1 comprises of a $12-\mu F$ capacitor and $1.16-mH$ inductance administered on the two sides of the capacitor. The circuit comprise of a diode rectifier and RL masses as demonstrated in Fig.11. The detached segments might be changed in accordance with make uncommon load conditions. The objective of this stage is to show the methods of operation of the EMS with stack step changes.

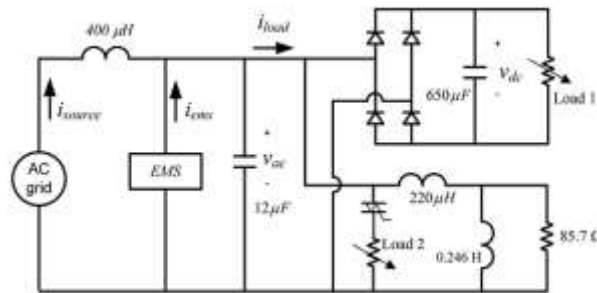

Fig.11. Circuit diagram for loads set up

Top shavings is accomplished by dominant the RMS current within the heap that is known with the source current. A limit is about for the heap gift, with the top goal that once the heap RMS current surpasses this edge, the EMS provides a little of the heap current.

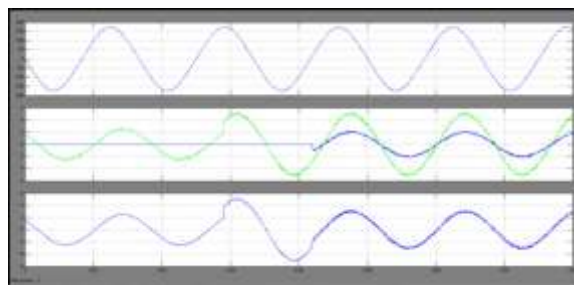

Fig.12. top shavings by EMS providing part of the load current from storage device once load will increase from 600 ohms to 80 ohms. For linear loads.

Load conditions for the simulation measurements in grid-connected mode

Fig.No.	Load 1	Load 2	AC grid
12	Infinity	Step from 600 to 80 ohms	ON
13	1200 ohms	Step from 1200 to 85.7 ohms	ON
14	Infinity	600 ohms	ON

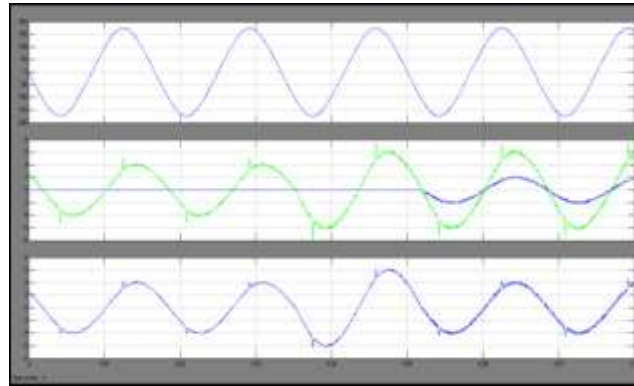

Fig.13.top shavings with the EMS giving a part of load current from battery module once the load will increase from 1200 ohms to 85.7 ohms, for nonlinear loads.

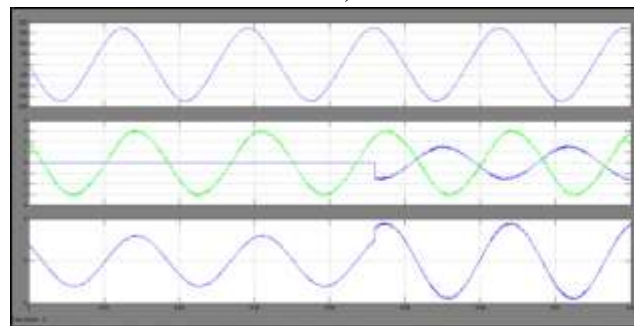

Fig.14. Battery charging mode.

Keeping in mind the top goal to grant energy to basic burdens once the ac system comes up short, the EMS identifies grid disappointment and goes regarding voltage hotspot for the fundamental burdens. During this technique of behaviour, non-critical burdens are shed contingent upon the condition of charge of the batteries and totally different parts management led by the shopper or by the auxiliary control system. The auxiliary management system decides whether or not the EMS ought to conceive to re connect to the ac grid or not.

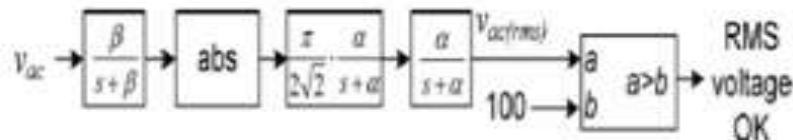

Fig.14.System for RMS voltge.

An additional programmed element that may be overseen by a additional elevated quantity regulator. There is a postponement within the dropping of the supply due to a lowpass channel utilized as a neighborhood of the identification calculation. The invention calculation is appeared in Fig.15.

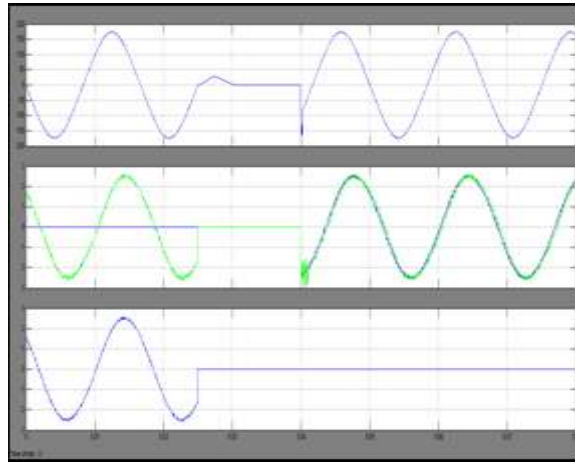

Fig.15.The system taking the loads into islanding mode

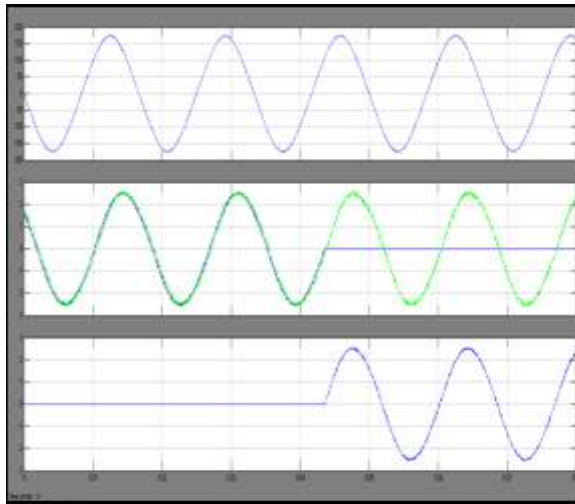

Fig.16. AC grid being fixed.

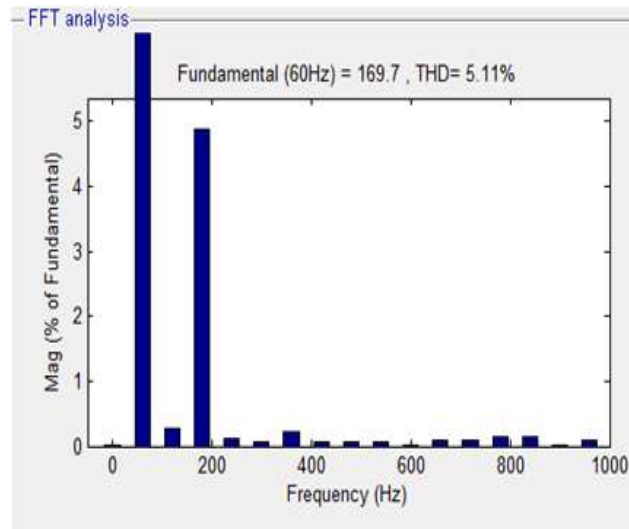

Fig.17. FFT analysis with PI controller

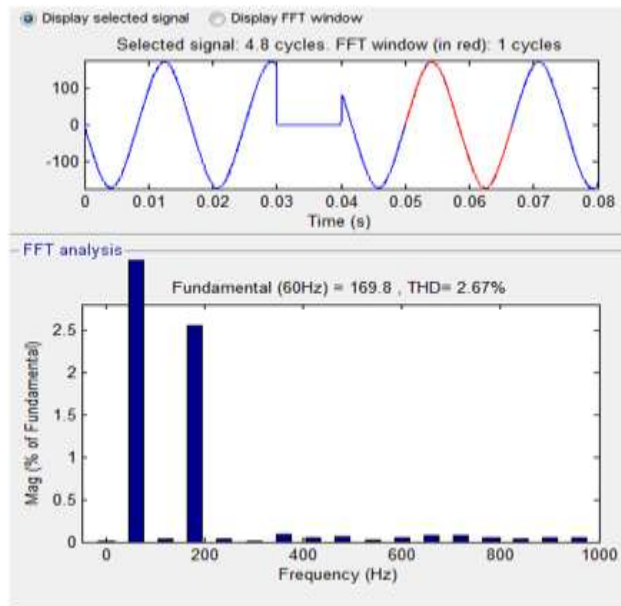

Fig.18. FFT analysis with fuzzy logic controller

The results obtained through the fuzzy controller are found to be low distortions and increasing the reliability and stability of the system.

CONCLUSION

In this paper power electronics based efficient energy management with fuzzy logic controller is exhibited with the help of simulation model. The management system supposed to play out the searching usage of traditional things is exhibited thoroughly. the EMS can finish different favorable undertakings, for example, top shaving. Exploratory estimations with straight and nonlinear burdens show how the EMS, controlled in current mode, gives a portion of the ability to the heaps to fulfill top shaving, in this manner decreasing the cost of power. A straightforward monetary examination is given in help of this announcement.

REFERENCES

- [1] .S. Vazquez, S. M. Lukic, E. Galvan, L. G. Franquelo, and J. M. Carrasco, "Energy reposition systems for bus and grid applications, IEEE Trans. Electron., vol. 57, no. 12, pp. 3881– 3895, Dec. 2010. Ind.
- [2] .J. Rocabert, A. Luna, F. Blaabjerg, and P. Rodriguez, "Control of energy converters in AC micro grids," IEEE Trans. Power lepton. vol. 27, no. 11, pp. 4734– 4749, Nov. 2012.
- [3]. F. Wang, J. L. Duarte, and M. A. M. Hendrix, "System Interfacing convertor systems with upgraded voltage quality for micro grid application— plan and implementation, IEEE Trans. Power lepton. vol. 26, no. 12, pp. 3501– 3513, Dec. 2011.
- [4] .E. Baklund N. Pogak M. Prodanovic, C. Hernandez-Arambro, and T. C. Green, "Energy administration in freelance microgrid utilizing Strength duty-bound droop management of inverters, IEEE Tran. Power lepton. vol. 23, no. 5, pp. 2346– 2352, Sep. 2008C
- [5] Y. Chen, Y. Wu, C. Melody, and Y. Chen, "Plan and execution of energy management system with downy management for DC micro grid systems," IEEE Trans. Power lepton. vol. 28, no. 4, pp. 1563– 1570, Apr. 2013.
- [6] B. I. Rani, G. S. Ilango, and C. Nagamani, "Control procedure for management stream administration during a PV system providing DC masses, IEEE Trans. Ind. Electron., vol. 60, no. 8, pp. 3185– 3194, Aug. 2013.



D. SUBBARAYUDU

Completed B.Tech in EEE in 2010 from KSRM college OF ENGINEERING, KADAPA. And pursuing M.Tech from JNTUA college of Engineering, Pulivendula, A.P., India. Space of interest electric power System.



SHAIK HUSSAIN VALI,

Completed B.Tech in EEE in 2007 from RGM college of Engineering and Technology, Nandyal. M.Tech in Machine Drives & Power electronics in 2009 from IIT Kharagpur. Working as Assistant professor in EEE in JNTUA college of Engineering, Pulivendula. Space of interest includes SMPS design, Digital control of Power Converters