

**THE POSSIBILITY OF MULTIPART-DRIVEN FLIP-FLOP INTEGRATION  
WITH CLOCK FUSION**

<sup>1</sup>Mr. Dr D.R.V.A.Sharath Kumar, <sup>2</sup>Mr. A.Sudhakar

<sup>1</sup>Professor & HOD, Electronics and Communication Engineering  
St.Martin’s Engineering College, Dhulapally, Secunderabad, T.S, India

<sup>2</sup>Assistant Professor, Electronics and Communication Engineering  
MLR Institute of Technology, Dundigal, Hyderabad, T.S, India

**ABSTRACT:** The clock gating is a main method used for strength saving. It is found that the commonly used synthesis based totally gating though leaves a variety of redundant clock pulses. Data-driven gating goals to disable those. To reduce the hardware overhead concerned, flip-flops (FFs) are grouped simply so they proportion a common clock permitting signal. The question of what is the group length maximizing the energy financial savings is answered in a preceding paper. Here we answer the question of which FFs need to be located in a hard and fast to maximize the power bargain. We propose a realistic solution primarily based at the toggling activity correlations of FFs and their bodily position proximity constraints within the layout. Our statistics-driven clock gating is protected into an Electronic Design Automation (EDA) business backend format waft, achieving total energy reduction of 15%–20% for diverse sorts of large-scale cutting-edge-day commercial and educational designs in 40 and sixty-five manometer technique generation.

**KEYWORDS:** Flip Flop, EDA, Clock Pulses, Maximum Power, Educational Design, and Automation.

**1. INTRODUCTION:**

With the fast boom in design complexity, computer-aided format tools supporting tool-level hardware descriptions have come to be usually used. Although appreciably developing layout productivity, such equipment requires the employment of a long chain of automatic synthesis algorithms, from join up switch stage (RTL) all the way down to gate stage and netlist [1]. Unfortunately, such automation leads to a big wide variety of useless clock toggling, for that reason increasing the range of wasted clock pulses at turn-flops (FFs) as demonstrated in this paper thru several industrial examples. Consequently, development of computerized and powerful strategies to reduce this inefficiency is right. In the sequel, we are able to use the terms toggling, switching, and interest interchangeably. When no longer being switched, the switching strength consumption is going to 0, and first-class leakage currents are incurred. Clock allowing indicators are usually added through manner of designers throughout the gadget and clock layout levels, wherein the inter-dependencies of the diverse functions are properly understood. In comparison, it’s far very tough to outline such alerts in the gate degree, mainly on pinnacle of things logic, due to the fact the inter-dependencies many the states of diverse flip-flops depend upon mechanically synthesized common sense [2][3]. There is a massive hole between block disabling that is pushed from the HDL definitions, and what can be accomplished with information knowledge concerning the turn-flops sports and the manner they’re correlated with every other.

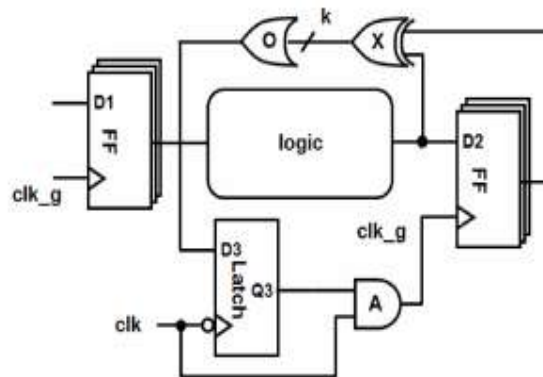

**Fig.1.1. Practical data-driven clock gating.**

## **2. RELATED STUDY:**

Clock tree consumes extra than 50 % of dynamic electricity. The components of this energy are, an energy fed on by combinational logic whose values are changing on every clock thing, Power consumed thru turn-flop sand, the power ate up through the clock buffer tree in the layout [4]. It is a splendid format idea to turn off the clock while it isn't always wanted. Automatic clock gating is supported thru modern-day EDA gear. They choose out the circuits wherein clock gating may be inserted. RTL clock gating works with the useful resource of figuring out groups of turn-flops which share a not unusual allow manage signal. RTL clock gating uses this permit sign to govern a clock gating circuit that is related to the clock ports of all the flip-flops with the common allow term. Therefore, if an economic organization of turn-flops which share a not unusual permit term have RTL clock gating finished, the turn-flops will devour zero dynamic power so long as this permit sign is false. The clock sign using an FF is disabled (gated) at the same time as the FFs country isn't difficult to trade in the next clock cycle. Data-pushed gating is inflicting area and electricity overheads that need to be taken into consideration. In a try to lessen the overhead, it's miles proposed to institution numerous FFs to be driven by means of the same clock signal, generated by means of oaring the enabling indicators of the person FFs. This also can, but, decrease the disabling effectiveness [5]. It is therefore useful to business enterprise FFs whose switching activities are relatively correlated and derive a joint permitting signal. In the brand-new paper, a model for statistics-driven gating is developed based on the toggling hobby of the constituent FFs [6]. The top of the line fan out of a clock gate yielding maximal power financial savings is derived based at the average toggling facts of the person FFs, method era, and cell library in use. In famous, the dominion transitions of FFs in virtual structures rely upon the information they method. Assessing the effectiveness of facts-pushed clock gating calls for, consequently, first rate simulations and statistical evaluation of the FFs' interest.

## **3. PROPOSED SYSTEM:**

Clock allowing signals are very well understood on the system level and for this reason can efficiently be defined and seize the durations in which useful blocks and modules do not need to be clocked. Those are later being robotically synthesized into clock enabling indicators on the gate diploma. In many instances, clock permitting signs are manually added for each FF as part of a layout methodology. Still, while modules at an immoderate and gate stage are clocked, the use of a transitions in their underlying FFs rely upon the facts being processed. It is crucial to notice that the entire dynamic electricity ate up via a gadget stems from the periods in which modules' clock signals are enabled [7]. Therefore, no matter how alternatively small this era is, assessing the effectiveness of clock gating requires huge simulations and statistical analysis of FFs toggling interest, as provided in the end. The best value of ok is received from underneath toggling independence assumption, but, the toggling can be correlated, so in practice, you likely can assume better saving than the theoretical lower sure acquired beneath independence assumption [8]. Furthermore, a practical layout approach should keep the integrity of machine clock allowing signs. This manner that the FFs of an adequate-size set need to all belong to the identical enabled clock (known as hereafter pre-enabled). We will first introduce a graph version observed with the aid of a device of the related optimization hassle. We then show the inherent trouble of the trouble. A scheme for constructing clock timber whilst the positions of the FFs in leaves are diagnosed is defined. A value function weighting the sum of clock sports and clock pin distances is minimized. Such a cost function is difficult because the bodily which means of a weighted sum of sports and distances isn't always well defined and requires sensitive tuning of the weights [9]. An opportunity of summing the products of the hobby through the use of the diameter of smallest circles enclosing FF devices seems more appropriate and is used in this paper. This sum of merchandise has the bodily devices of powerful capacitance, consequently explicitly measuring electricity consumption, and no weights are wanted.

## **4. SIMULATION RESULTS:**

As noted in advance, the gating scheme might also have significant timing implications. Potential timing violations are averted the usage of Step three of the flow proposed in Section IV, which corporations FFs primarily based on the initial favoured locations of FFs in the format discovered with the aid of Step 2. Such restrict increases the wide variety of redundant clock pulses, however this is compensated through shortening the wires connecting the clock gates to their corresponding FFs. To compares grouping with and without FF vicinity constraints, for a layout comprising four.9 okay FFs and a look at of a hundred and five clock cycles, displaying a 5%–10% increase within the redundant pulses. This has handiest a little effect at the saving measured in the simulation.

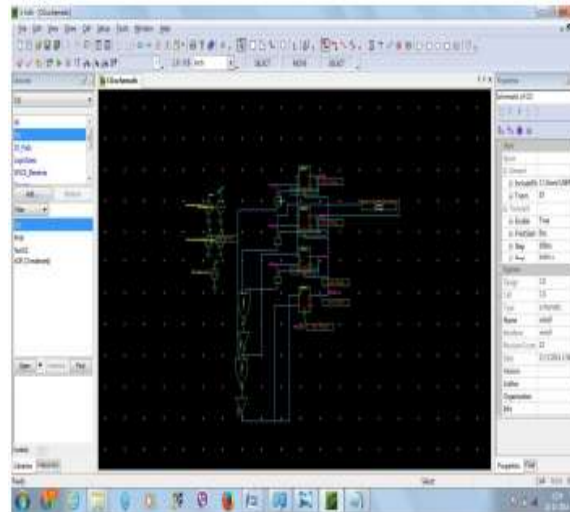

**Fig.4.1 Simulation circuit.**

The schematic design of clock gating for low energy systems and it shows the operation of circuit BY the use of gating methods. On this the clock pulse from clock distribution community is given to XOR GATE. Figure shows the output waveform of clock gating circuit energy consumed by means of using this approach is two.473965e-010 watts.



**Fig.4.2. Output wave forms.**

### 5. CONCLUSION:

In this facts-driven clock gating technique is used to reduce the amount of redundant clock pulses and the quantity of transistors, so the electricity dissipation additionally reduced. All the flip-flops are grouped via the usage of giving commonplace clock pulse so the vicinity is decreased; extra in particular looks at the actual submit clock tree timing facts of clock not unusual experience at placement diploma, which permits pleasant placement and optimization for clock commonplace feel. Also, seeing the timing slack it offers a maximum latency of clock excellent judgment for better clock tree and for this reason timing results. It makes use of XOR gate in case you need to disable the flip flop. Disabling effectiveness is higher. Clock gating saves greater electricity while in comparison with distinct techniques which offer higher overall performance in terms of region and electricity. In my destiny paintings strength gating may be used. In a processor chip, positive regions of the chip might be idle and can be activated best for certain operations. However, those regions (comes) are although provided with electricity for biasing. The power gating limits this unnecessary strength being wasted through shutting down power for that location and resuming every time needed.

**REFERENCES:**

- [1] V. G. Oklobdzija, *Digital System Clocking—High-Performance and Low-Power Aspects*. New York, NY, USA: Wiley, 2003.
- [2] L. Benini, A. Bogliolo, and G. De Micheli, “A survey on design strategies for system-degree dynamic electricity management,” *IEEE Trans. Very Large Scale Integr. (VLSI) Syst.*, vol. 8, no. Three, pp. 299–316, Jun. 2000.
- [3] M. S. Hosny and W. Yuejian, “Low energy clocking strategies in deep submicron technology,” in *Proc. IEEE Intll. Conf. Integr. Circuit Design Technol.*, Jun. 2008, pp. 143–146.
- [4] C. Chunhong, K. Changjun, and S. Majid, “Activity-sensitive clock tree production for low strength,” in *Proc. Int. Symp. Low Power Electron. Design*, 2002, pp. 279–282.
- [5] A. Farrahi, C. Chen, A. Srivastava, G. Tellez, and M. Sarrafzadeh, “Activity-driven clock layout,” *IEEE Trans. Comput.-Aided Design Integr. Circuits Syst.*, vol. 20, no. 6, pp. 705–714, Jun. 2001.
- [6] W. Shen, Y. Cai, X. Hong, and J. Hu, “Activity and sign up placement conscious gated clock community layout,” in *Proc. Int. Symp. Phys. Design*, 2008, pp. 182–189.
- [7] M. Donno, E. Macii, and L. Mazzoni, “Power-aware clock tree making plans,” in *Proc. Int. Symp. Phys. Design*, 2004, pp. 138–147.
- [8] SpyGlass Power [Online]. Available: <http://www.Atrenta.Com/answers/spyglass-own family/spyglass-power.Htm>.
- [9] S. Wimer and I. Koren, “The Optimal fan-out of clock community for energy minimization with the aid of adaptive gating,” *IEEE Trans. Very Large Scale Integr. (VLSI) Syst.*, vol. 20, no. 10, pp. 1772–1780, Oct. 2012