

**Parameter Improvement of MPA using Square Shape Reflector for S-Band
Wireless Application**

Shrawan Kumar Patel¹

¹Department of ECE, School of Engg. & Tech., GGV Bilaspur (CG),

Abstract - A low profile MPA have been widely used for the application of RF and wireless system because of their small size, light weight and easy realization. In this project, a metal based reflector resonator is used to increase antenna gain by 2.796 dBi at 2.73 GHz resonant frequency. The proposed patch antenna is operating in 2.7GHz frequency band with impedance bandwidth of 2.6-2.73GHz. Parametric analysis of reflector height is done in order to obtained peak gain of 4.97dBi. The radiation of patch antenna shows broadside pattern with stable gain such that the antenna is suitable for wireless application in s- band. The proposed antenna design is simulated on CST software using FR4 substrate with relative permittivity of 4.3 and thickness of 1.6mm.

Keywords – MPA, Reflector Resonator, Antenna Gain, Impedance Bandwidth, Wireless Application.

INTRODUCTION

Microstrip antennas are planar resonant cavities that leak from their edges and radiate. Printed circuit techniques can be used to etch the antennas on soft substrates to produce low-cost and repeatable antennas in a low profile. In its most basic form, a Microstrip patch antenna consists of a radiating patch on one side of a dielectric substrate which has a ground plane on the other side.[8] The patch is generally made of conducting material such as copper or gold and can take any possible shape. The radiating patch and the feed lines are usually photo etched on the dielectric substrate. A patch radiates from fringing fields around its edges. The situation is shown in figure. Impedance match occurs when a patch resonates as a resonant cavity. When matched, the antenna achieves peak efficiency. For good antenna performance, a thick dielectric substrate having a low dielectric constant is desirable since this provides better efficiency, larger bandwidth and better radiation.[2,3] However, such a configuration leads to a larger antenna size. In order to design a compact Microstrip patch antenna, higher dielectric constants must be used which are less efficient and result in narrower bandwidth. Hence a compromise must be reached between antenna dimensions and antenna performance.[6] There are numerous techniques to increase the antenna gain such as antenna array design, horn mounted patch antenna, metamaterial based superstrate, etc.[5] In order to increase the gain of antenna in the proposed design a square shaped metal parasitic resonator place above the antenna whose height is optimized using parametric variation.[7] The antenna with metal reflector placed above is acting as a highly reflective lens which forms a high reflection magnitude cavity and thus helps to increase the gain of antenna.[7,8]

ANTENNA DESIGN & SIMULATION RESULTS

A microstrip patch antenna designed with specified dimensions which resonates in the frequency range of S-band applications i.e. 2.73GHz. Patch and ground are made of copper having thickness 0.017 mm and 1.6 mm respectively. Material used for substrate is taken as FR-4 having relative permittivity 4.3. transmission line feeding technique used as feed line. The directivity, gain of single patch is 6.4 dBi and 2.174 dB respectively. The antenna design and respective results are shown in figure 1, 2 and 3.

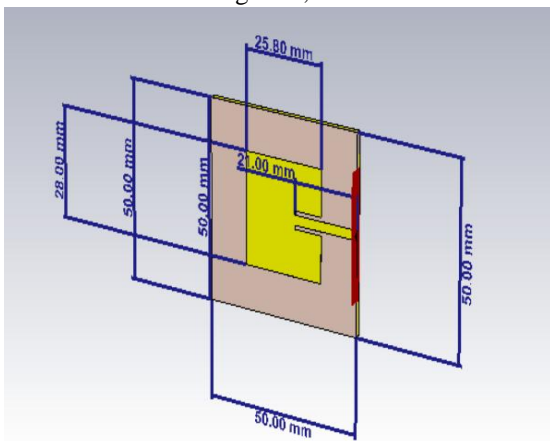

Fig. 1 Proposed Microstrip Patch Antenna

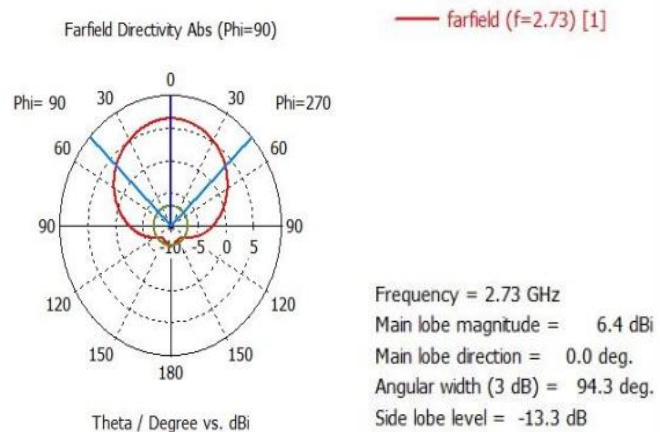

Fig. 2 Farfield Radiation Pattern of Proposed Antenna

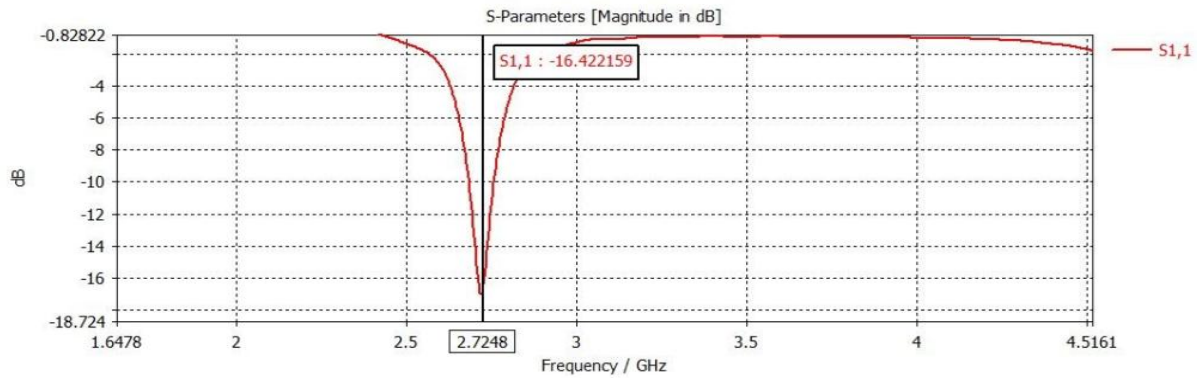

Fig. 3 S- Parameter/return Loss of Proposed Antenna

SQUARE SHAPE REFLECTOR DESIGN & RESULT

A square shape reflector is a metal layer designed specifically to enhance the antenna parameter like gain & directivity. The metal reflector is acting as a highly reflective lens which forms a high reflection magnitude cavity and thus helps to increase the gain of antenna when it is placed over the antenna at any specific height. The size of reflector is optimized to $15 \times 15 \text{ mm}^2$ and placed at height of 12mm above patch surface to obtained peak gain increment of 2.796dBi at 2.7GHz resonant frequency. The reflector placed above antenna does not change the impedance bandwidth of original square patch antenna. The far field radiation and other results of antenna with reflector are shown in figure 4, 5 and 6.

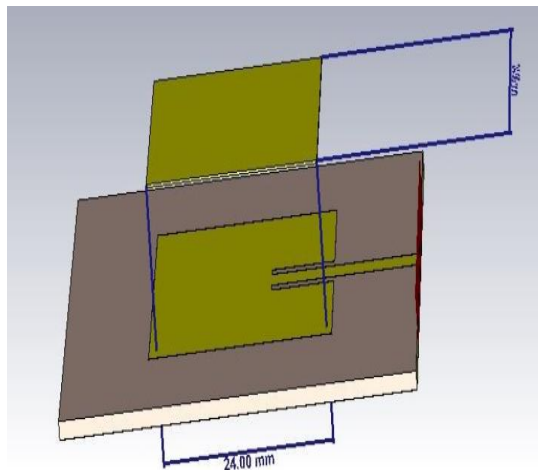

Fig.4 Proposed MPA with Square shape reflector

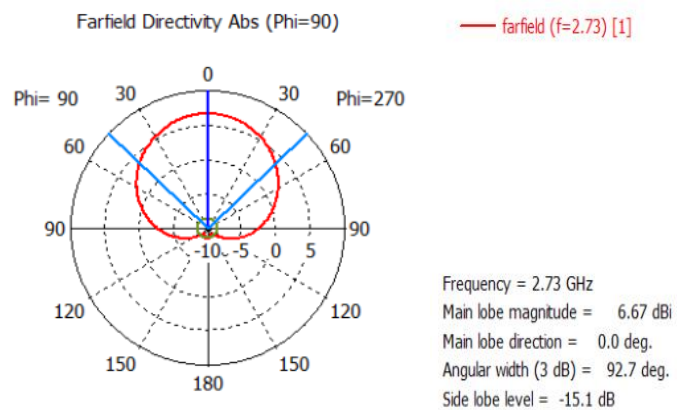

Fig. 5 Farfield Radiation Pattern of MPA with reflector

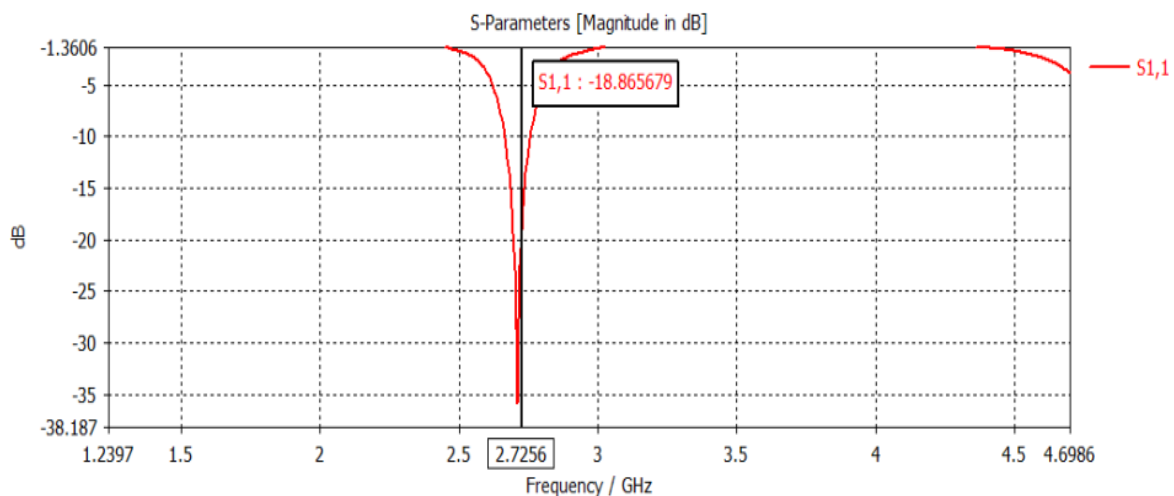

Fig. 6 S- Parameter/return Loss of Antenna with Square shape reflector

On increasing the distance between patch and the square shaped metallic reflector (H), the gain and directivity of the microstrip patch antenna increases up to (H=-3 to H=12). But on further increasing the distance the same value of gain and directivity gets decreased. Even for decreasing the value of H beyond H=-3 the value of gain and directivity gets decreased. Hence, it is concluded that the gain and directivity of the microstrip patch antenna increases till H=12 and obtain the maximum 2.796 dBi increment in gain. The values of gain and directivity for different values of H are listed in the comparison table below:

TABLE I
COMPARISON TABLE

ANTENNA PARAMETER	H=-3	H=3	H=5	H=10	H=12	H=15
S-PARAMETER	-22.59	-13.21	-10.52	-12.08	-12.87	-14.1
GAIN	2.61	3.9	4.2	4.83	4.97	4.65
DIRECTIVITY	6.456	6.91	7.03	7.29	7.33	7.5
FARFIELD SIDELobe	-13.3	-16.4	-16.6	-15.1	-14.2	-11.7

CONCLUSIONS

As gain enhanced micro strip patch antenna using metal reflector is studied and designed. The metal reflector layer is placed at height of 12mm above patch antenna to obtained peak gain of 4.97dBi with gain increment of 2.796 dBi. The proposed design is verified using CST Microwave studio with impedance bandwidth (2.6-2.78GHz). The proposed design offers suitable candidate for high gain wireless applications like in mobile satellite communication, Direct broadcast television, Wireless LANs, GPS system, Missile and telemetry and UHF patch antenna for space etc.

REFERENCES

- [1] M T Ali, H. Jaafar, S. Subahir, and A.L.Yusof, "Gain Enhancement of Air Substrates at 5.8GHz for Microstrip Antenna Array" *Proceedings of 2012 IEEE Asia-Pacific Symposium on Electromagnetic Compatibility*, pp: 477-480.
- [2] Ruchika Gupta, Mithilesh Kumar, "Bandwidth Enhancement of Microstrip Patch Antennas by Implementing Electromagnetic Bandgap (EBG) Structures" *Proceedings of Fourth International Conference on Computational Intelligence and Communication Networks*, November 03 - 05, 2012
- [3] M Asaadi, I.Afifi, and A.R. Sebak, "High Gain and Wideband High Dense Dielectric Patch Antenna Using FSS Superstrate for Millimeter-Wave Applications" *IEEE Access*, Vol.6, pp. 38243 – 38250, July.2018.
- [4] A Chatterjee and S. K. Parui, "A Dual Layer Frequency Selective Surface Reflector for Wideband Applications", *Radio engineering*, Vol. 25, no.1, pp. 67-72, Apr. 2016.
- [5] D. Li, Z. Szabo, X. Qing, Er. P. Li and Z. N. Chen "A high gain antenna with an optimized metamaterial inspired superstrate", *IEEE Trans Antennas Propag.*, Vol. 60, no. 12, pp.6018- 6023 Dec. 2012.
- [6] P. Das and K. Mandal, "Modeling of ultra-wide stop-band frequency selective surface to enhance the gain of a UWB antenna" *IET Microwaves, Antennas Propagation*, Vol. 13, no.3, pp. 269-277, Feb 2019.
- [7] R. Mark, N. Rajak, K. Mandal and S. Das, "Metamaterial based superstrate towards the isolation and gain enhancement of MIMO antenna for WLAN application" *Int. J. Electron. Commun. (AEÜ)*, Vol.100, pp.144-152, Feb.2019.
- [8] Balanis C.A., *Antenna Theory Analysis and Design*, John Wiley & Son,2005