

Manufacturing of Gear in Lathe using Aurdino

Niveda.K¹, Praveen Babu.S², Sam Ashwin.A³, Vibin P.B⁴

¹²³⁴Ug scholar

¹²³⁴Department of Mechanical Engineering, KGiSL Institute of Technology

Abstract—The important of manufacturing process is that without it no products reach to customer satisfaction. Hence for the Engineers it is importance to convert design into actual product and this is possible only when we go through suitable manufacturing process. Hence manufacturing process is value addition process in which raw materials gets converted into finished goods. Gear is important element of mechanical power transmission. It is manufactured by many processes such as casting, milling, hobbing and shaping. All these manufacturing has its own importance. Among these manufacturing milling is preferred most for job or small production. This milling machine is costly we have making a new attachment which make gear when installed on lathe carriage using aurdino and stepper motor. This one is cheap device hence avoids dependency on costly milling machine for job production.

Keywords— Design, Calculation, Fabrication & Source code

I. INTRODUCTION

The lathe attachment will be built from the ground up to maximize the efficient use of space. This has leads to increase in setup of large number of various industries, most of them are small scale industries and small workshops which provide various services to different large scale industries. Cost reduction is the one of the major factor that is consider in setup of small scale industries and small workshops We approached our design by considering all possible alternatives for a system & modeling them in CAD software like SOLIDWORKS. The design process of the project is based on the availability, cost and other such factors. So the design process focuses on following objectives:

II. MATERIAL AVAILABILITY

Si no	Materials	Quantity
1	DC stepper motor	1
2	Arduino board	1
3	Shaft	1
4	Acrylic board	1
5	Coupling	1
6	Set screws	1
7	Flange	1
8	Bearing	1
9	Battery	1
10	Male connector pin	1

Acrylic board is used to hold the setup of motor and microprocessor. As our setup is a prototype acrylic board was selected due to its exceptional weatherability, strength, clarity and versatility. The stepper motor can hold their position and resist rotation. A full 360° circle divided by the step angle gives the number of steps per revolution. Arduino consists of both a physical programmable circuit board (often referred to as a microcontroller) and a piece of software, or IDE (Integrated Development Environment) used to write and code to the physical board.

III. DIFFERENT PROJECTIONS OF LATHE ATTACHMENT

Organized by Kgisl Institute of Technology, Affiliated to Anna university, Coimbatore, Tamilnadu

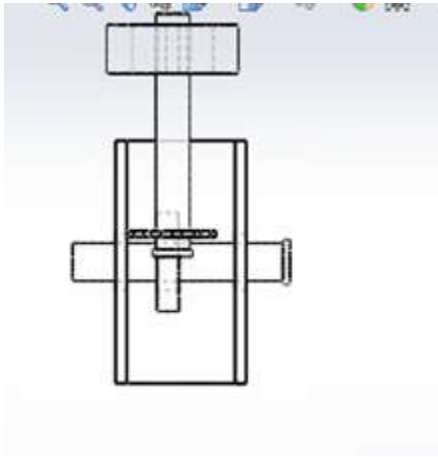

Fig.1 top view of lathe attachment



Fig.2 front view of lathe attachment

IV. CAD MODELLING

Computer aided design (CAD) is the use of computer systems to assist in the creation, modification, analysis or optimization of a design.

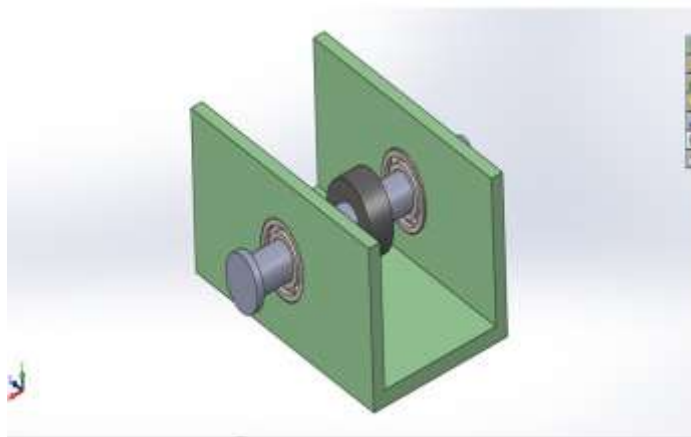

We approached our designs by considering all possible alternatives for system and modelling them in CAD software like Solid works

V. CALCULATION

A. DESIGN OF SHAFT

For solid shaft strength,

$$P = \frac{2\pi NT}{60}$$

Where ;

P = Power

N = Maximum rpm

T = Torque

$$3.44 = \frac{(2 \times 3.14 \times 100 \times T)}{1000}$$

$$T = 0.547 \text{ N-m}$$

Shear strength of the shaft,

$$\tau = (MT/\pi d^3)$$

Where ;

τ = shear strength

M = modulus of rigidity

T = torque

$$\tau = \frac{7800 \times 0.547}{\pi \times 8 \times 8 \times 8}$$

$$\tau = 26.526 \text{ N/mm}^2$$

Maximum shear strength of mild steel is between 200 to 250, and we have got below that, so it is safe to use.

B . CALCULATION FOR INDEXING

Blank diameter

$$(Z/ \cos \alpha + 2)m$$

Where ,

Z = number of teth required

M = module

Indexing for 60 degree = 60/ 9

$$= 6 \frac{2}{3}$$

6 full turns plus 12 holes on 18 hole circle

VI.SOURCE CODE FOR AURDINO

SOURCE CODE :

```
#include<stepper.h>
#define STEPS100
Stepper(STEP,2,3,4,5);
const int button=7;
int buttonstate=0;
void setup()
{
stepper.setspeed(100)
Pinmode(button,INPUT);
}
Void loop()
{
If(buttonstate==HIGH)
{
Stepper.step(100);
Delay(700);
}
Else
{
Stepper.step(0);
}
}
```

VI.CONCLUSION

Thus, this report provides a clear insight in design of our project. The basic aim was to formalize a methodology to facilitate the automation of such design process., The proposed methodology for fixture design process will fulfilled researcher production target and enhanced the efficiency, hydraulic fixture reduces operation time and increases productivity, high quality of operation, reduce accidents.

REFERENCES

- Mr.S.Gadakh Ramesh, Mr. G. LondhePradip, Mr.A.Shaikh Bilal, Mr. S. ShaikhFiroj, Lecturer, Department of Mechanical Engineering, A.T.C.F.O.E, Chas Ahmednagar Maharashtra, India.
- *Gear Nomenclature, Definition of Terms with Symbols*. American Gear Manufacturers Association. p. 72. ISBN 1-55589-846-7. OCLC 65562739. *ANSI/AGMA 1012-G05*.
- Jig and Fixture Design By Hamad Mohammed Abouhenidi **St. Mary's university**
- International Journal of Advanced Research in Computer and Communication Engineering Vol. 5, Issue 4, April 2016 Copyright to IJARCCCE DOI 10.17148/IJARCCCE.2016.5416 61 A Review on Types of DC Motors and the Necessity of Starter for Its Speed Regulation Kriti Shrivastava1 , Prof M.D Pawar2 M-Tech Student, ENTC, MIT (T), Aurangabad, India1
- Design of Vehicle Power Transmission System J. S. Freeman and S. A. Velinsky[+] Author and Article Information.*J. Mech. Des* 117(B), 113-120 (Jun 01, 1995) (8 pages)doi:10.1115/1.2836443History: Received November 01, 1993; Online January 24, 2008
- Victorian restrictions on probationary drivers". Vicroads.vic.gov.au. 2014-01-14. Archived from the original on 2014-08-01. Retrieved 2014-04-29.
- *Marshall Brain*. "How Sequential Gearboxes Work". *Howstuffworks.com*. Retrieved July 2, 2013.