

HYBRID CONNECTION OF NON -CONVENTIONAL SOURCES TO GRID AND LOAD BY USING SINGLE STAGE CONVERTER

M.KONDAIAH, *PG Student, Dept of EEE, ANU College of Engineering & Technology,
Guntur Dt, A.P, India.*

R S SRINI, *Assistant Professor, Dept of EEE, ANU College of Engineering & Technology,
Guntur Dt, A.P, India.*

Abstract - *This concept originates the converter Single stage converter called as reconfigurable solar converter (RSC) suitable for power management strategies of a single stage three phase grid-tie converters with an additional Wind, PV-Battery ideology to enforce DC/AC and DC/DC operations.*

Solar Wind power passes a courageous and advanced path to all nations instructively ensuing power autonomy with pure and continuous power results-One that conquer the current rectifications of known other sources and can produce the power up to 1,250MW. In the tower the wind generated by the air touches the turbine at particular compelling speeds-Powering generators to get enormous power. And this integration of neoteric converter minimizes the number of conversion stages there by that developing system's capability and decreasing expenditure, burden, also size of the system.

The modish converter of this project verifies that the DC/DC converter can charge and discharge properly from Zero to the rating voltage without using any external pre charging circuit. Due to this reason the maximum power is achieved by tracking the PV array.

Index Terms—*Converter, photovoltaic (PV), Wind turbine, Battery, Load, Grid.*

Received: 25/06/2021, **Accepted:** 14/07/2021, **Published:** 22/07/2022

I. INTRODUCTION

With the increasing fossil fuel deficit, global warming and damage to the ecosystem, renewable energy sources (solar, wind, tidal, and geothermal, etc.) are attracting more attention as alternative energy sources. Among the renewable energy sources solar photovoltaic (PV) energy has been widely utilized in small-sized applications. It is also the most promising candidate for research and development for large-scale uses as the fabrication of less costly photovoltaic devices becomes a reality.

Naturally the wind and photovoltaic systems having one disadvantage that the systems are inaccurate in nature. By integrating MPPT algorithm, however by merging these two systems, the system's power reconstructing capability and accuracy can be enhanced much. The integration of renewable energy sources and energy-storage systems has been one of the new trends in power-electronic technology. The increasing number of renewable energy sources and distributed generators require new strategies for their operations in order to maintain or improve the power-supply stability and quality.

By integrating more number of renewable recourses with a natural DC bus comparing with a natural Ac type power transfer has been extensive so that of easy in monitoring and control and easy to understand in structure. Several methodologies are developed for optimal design or unit sizing.

This project addresses dynamic modelling and control of a grid-connected wind–PV–battery hybrid system by maximum power solution. This integrated process possible to inject the power into the grid and it is constant.

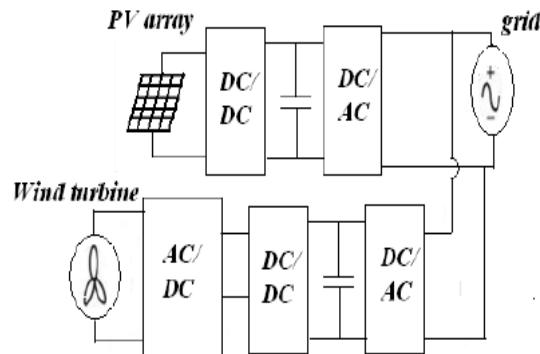

Fig1. Block diagram of AC-shunted grid connected hybrid PV/wind energy system

Most applications are for stand-alone operation, where the main control target is to balance local loads. A few grid-connected systems consider the grid as just a back-up means to use when there is insufficient supply from renewable sources. They are originally designed to meet local load demands with a loss of power-supply probability of a specific period. Such hybrid systems, focusing on providing sustainable power to their loads, do not care much about the quality or flexibility of power delivered to the grid. From the perspective of utility, however, a hybrid system with less fluctuating power injection or with the capability of flexibly regulating its power is more desirable. In addition, users will prefer a system that can provide multiple options for power transfer since it will be favourable in system operation and management. Control strategies of such a hybrid system should be quite different from those of conventional systems.

In order to effectively achieve such modes of operation, two modified techniques are applied; a modified hysteresis control strategy for a battery charger/discharger and a power averaging technique using a low-pass filter. This amalgam system’s concept and ethic and its departmental control are described. Classical techniques of maximum power tracking are applied in PV array and wind-turbine control. Dynamic modelling and simulations were based on Power System Computer Aided Design/Electromagnetic Transients Program for DC (PSCAD/EMTDC), power-system transient-analysis software. The program was based on Dommel’s algorithm, specifically developed for the simulation of high-voltage direct current systems and efficient for the transient simulation of power system under power-electronic control.

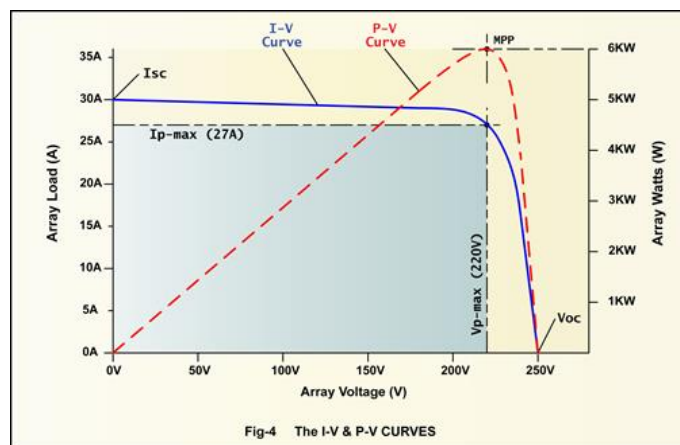

Fig.2. V-I & P-V Curve graph

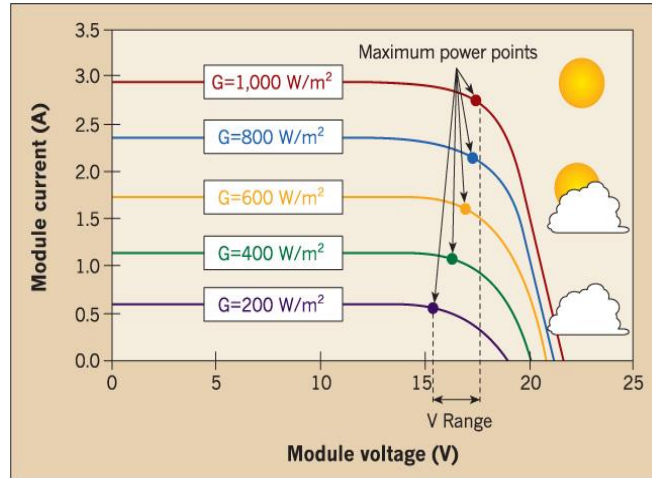

Figure3:PV array (I –V) characteristics at various insolation level

There are various methods for integrating energy storage into a utility-scale solar PV system. [15]

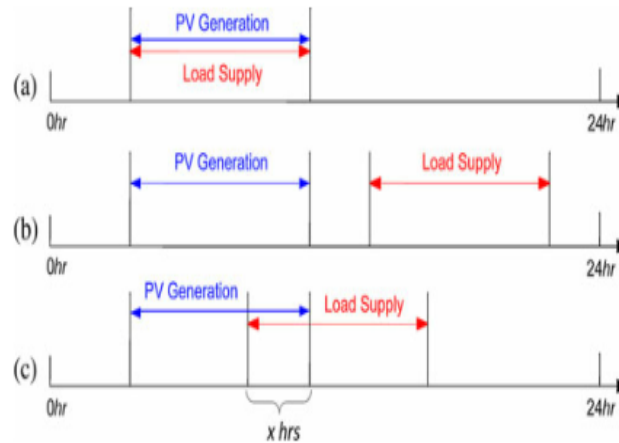

Fig. 4.Different scenarios for PV generation and load supply sequence. Stages [4]–[33].

The key approach of the RSC is to avail a single power reconstruction system to give various operation modes such as PV to grid (dc to ac), wind to grid, PV/wind to grid, PV/wind to battery (dc to dc), battery to grid (dc to ac), and battery/PV/wind to grid (dc to ac) for solar PV/wind systems with energy storage. The RSC thought emanate from the fact that energy storage integration for utility-scale solar PV systems makes sense if there is an enough gap or a minimal overlap between the PV energy storage and release time shown in fig 2(a,b,c)

II. NEOTERC RECONFIGURABLE SOLAR CONVERTER (RSC) FOR WIND, PV-BATTERY

A. Introduction

The schematic of the neoteric RSC is conferred in Fig. 2. This neoteric converter shows the modes of operations to flow the maximum power to the grid at any instant of time by using the MPPT algorithm for wind/PV Battery applications. So that it will give the maximum efficiency with low cost reliability in whole day.

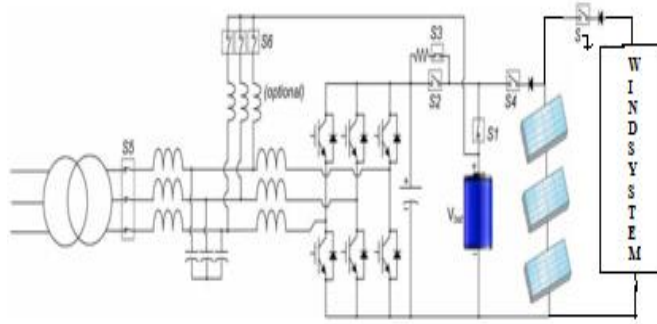

Fig. 5.Schematic of the proposed RSC circuit.

B. Transaction state of the RSC

All achievable transactions states for the RSC are conferred in Fig. 3. In the first mode of operation S_1, S_7 and S_6 switches remain open gives the maximum power to the grid by using the PV directly which is possible with MPPT control through dc/ac transaction. If it can't possibility to give maximum power to the grid when the whether radiation of Sun not supported then it will go to the second mode of operation. In the second state The Wind is directly connected to grid gives the maximum power in the same manner of mode1 but S_4 open. In mode3 PV and Wind both gives the power to grid. In mode4 PV/Wind charges the battery through dc/dc operation by using the dc/dc boost converter y opening the S_6 and S_5 . In mode 5 the battery gives the power to grid. One more mode is PV/Wind/Battery to grid.

C. System benefits of solar PV power plant with the RSC approach

The RSC notion lends momentous benefits to system planning of utility-scale solar PV power plants. The current state-of-the-art technology is to integrate the energy storage into the ac side of the solar PV system. [15]

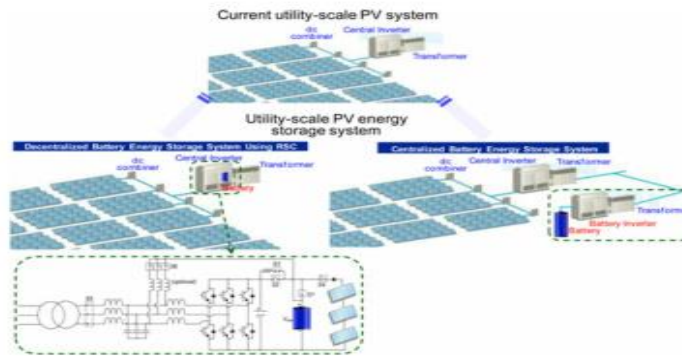

Fig. 6.Utility-scale PV-energy storage systems with the RSC and the current state-of-the-art solution.

III. HYBRID SYSTEM CONTROL AND CONFIGURATION

A typical hybrid power generation system is shown in Fig.

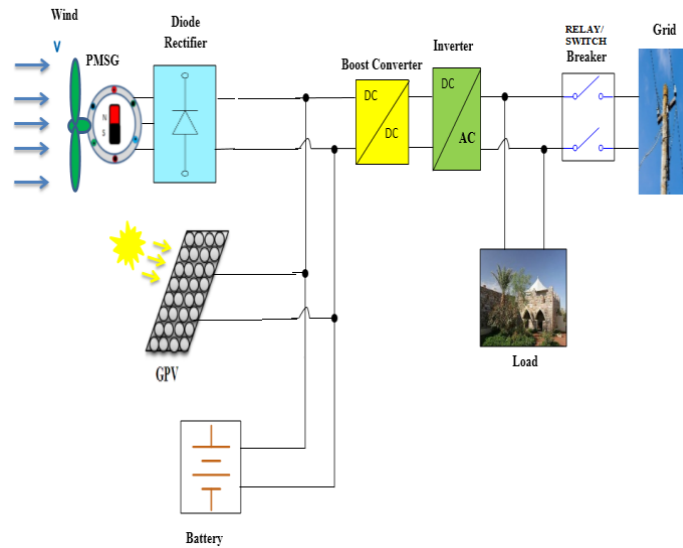

Figure 7. The studied hybrid system configuration

In this project the PQ controller is used for active and reactive power control. The Dc link voltage is used for determining the output voltage of the VSI and voltage drop across the filter. vdc reference frame using park transformation. The Phase Locked Loop (PLL) measures the grid voltage phase angle the dc link voltage is measured and compared to dc link reference voltage. The error in the dc voltage is fed to a PI controller which provides d axis current reference. LC filter is used at the inverter output to improve the quality of waveform.

IV. PHOTOVOLTAIC MODEL

Largest renewable energy appears either directly or indirectly from the sun. For creating electricity and for warm water heating and solar cooling, solar energy can be helped. This energy is composed when the sun is gleaming all along the day and is reciprocal to wind energy, which contributes to grasp its maximum production at night. The photovoltaic effect is the generation of a voltage (or a corresponding electric current) in a material upon exposure to light.. In the photoelectric effect, electrons are ejected from a material's surface upon exposure to radiation of sufficient energy. The photovoltaic effect is different in that the generated electrons are transferred between different bands (i.e. from the valence to conduction bands) within the material, resulting in the buildup of a voltage between two electrodes. In most photovoltaic applications the radiation is sunlight and for this reason the devices are known as solar cells. In the case of a p-n junction solar cell, illumination of the material results in the generation of an electric current as excited electrons and the remaining holes are swept in different directions by the built-in electric field of the depletion region. The photovoltaic effect was first observed by Alexandre-Edmond Becquerel in 1839. Though the photovoltaic effect is directly related to the photoelectric effect, the two processes are different and should be distinguished

A. Production of solar energy

Photovoltaic solar: This automation benefits photovoltaic cells (PV) to change sunrays into electricity. These PV cells are created by semiconductor material and can give enormous power for the electric grid.

By using solar power

Solar energy is eco friendly system it does not affect the earth. Abusing of Air and water is reduced by maintaining solar energy and also greenhouse gases are eliminated. Solar energy is calculable and is most powerful when applicability rates are the maximum.

V. WIND SYSTEM

Wind and solar energy procedures are efficient in maximum power production that can expand our nation's energy briefcase. However, it's a serious challenge for producing continues power growth of renewable energy in the U.S. because of the lack of changes. By using the wind and solar energy project produces the maximum energy and direct current that lack access to new, very good power with minimum cost.

There was Windmills used commonly in 20th century across the plants to pump and generate electricity. The motion of air is produced wind by normal causes same as to irregular warming of earth's surface by the sun. Wind energy is very useful to carry ships, pump water and grind. The turbine blades are shifted when the wind hurricanes and blades are given to the shaft to move and create electricity in the form alternating current.

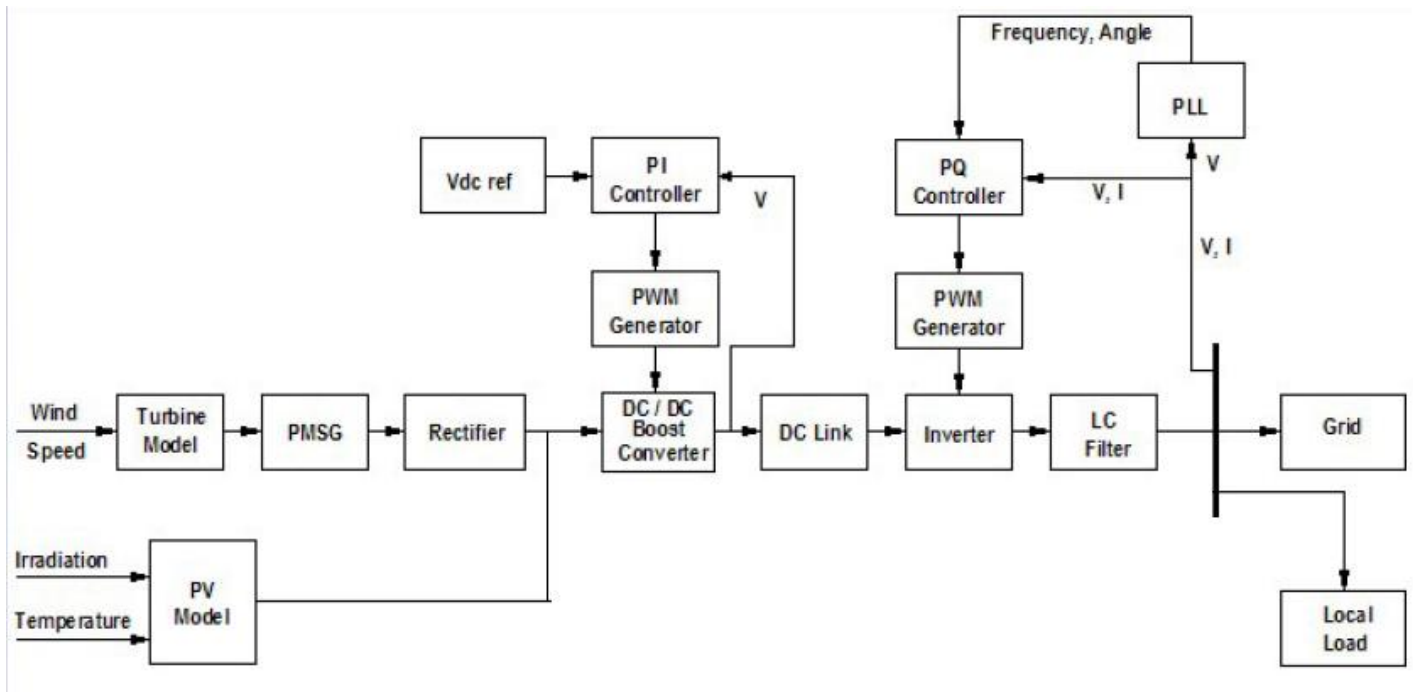

Figure 10. Overall Block diagram of the power management strategy for Wind/PV battery applications

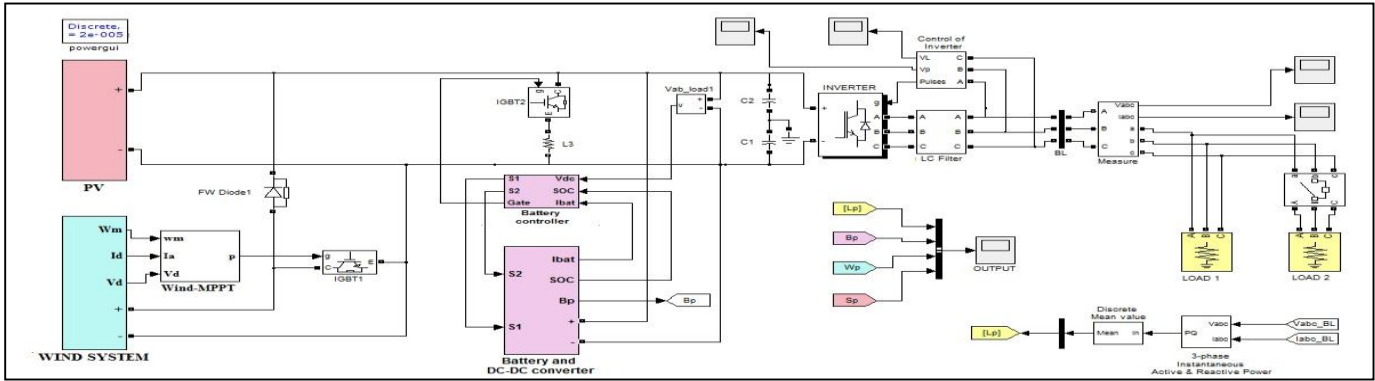

Fig 11 Simulation modal for the Wind/PV-Battery concept

SIMULATION RESULTS:

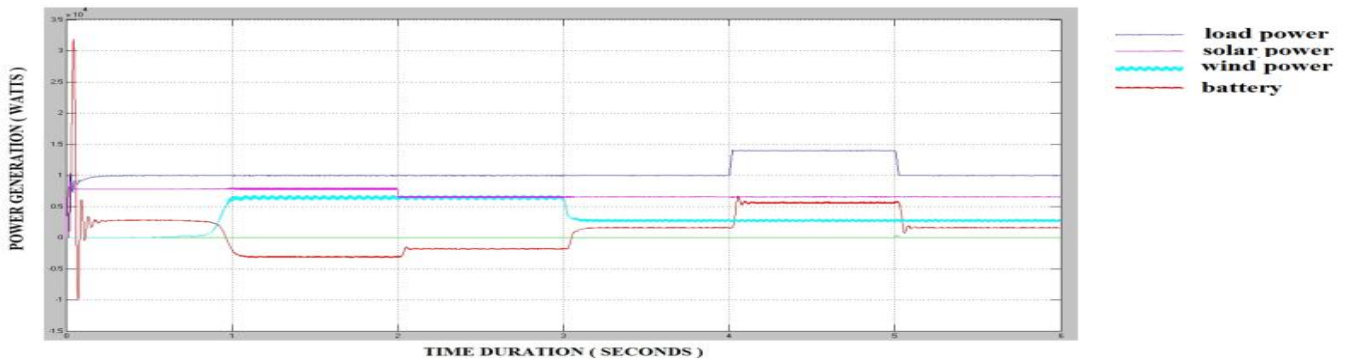

Fig 12 Solar Panel Power response of the load, wind, PV, battery system.

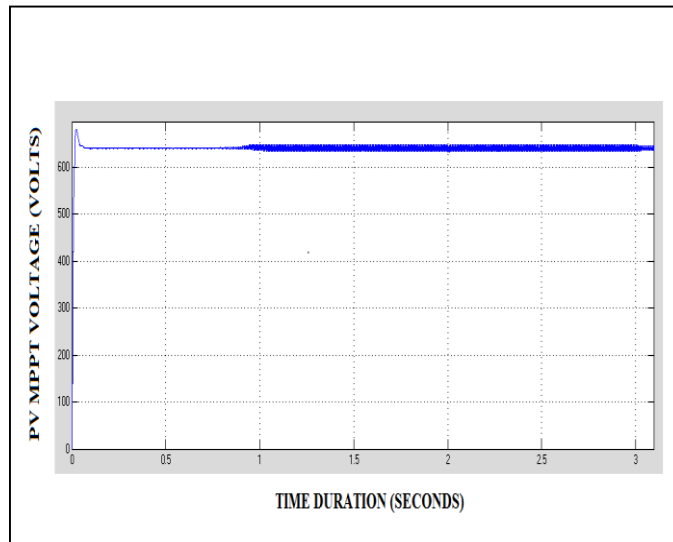

Fig 13 PV array's phase voltage.

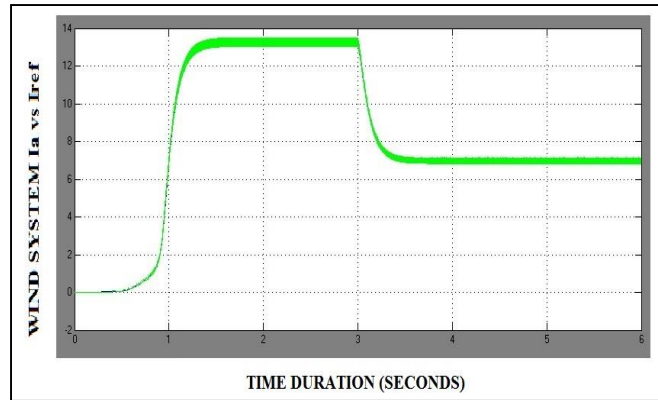

Fig 14 Actual Current (I_a) and Reference Current's (I_{ref}) The Relative variation curve.

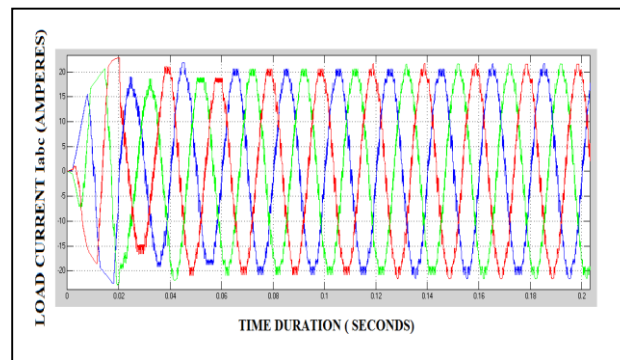

Fig 15 Simulation results of sinusoidal load current

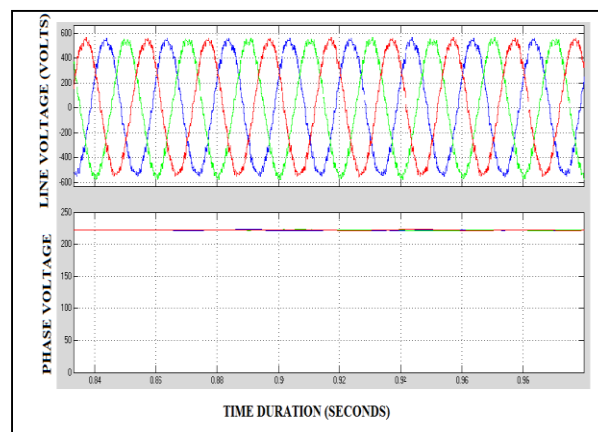

Fig 17 Inverter's line and phase voltage of AC

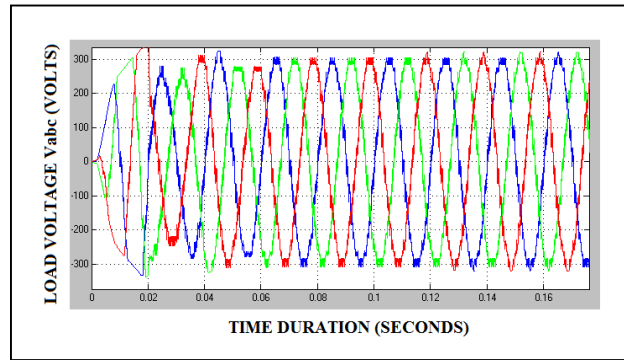

Fig 16 Inverter' three phase voltage through load

VII. CONCLUSIONS

. In The Proposed Paper Load Demand Is Met From The Combination Of PV Array, Wind Turbine And The Battery. An Inverter Is Used To Convert Output From Solar Systems Into AC Power Output. Circuit Breaker Is Used To Connect An Additional Load Of 5 KW In The Given Time. Either Solar System Is Supported By The Battery To Meet The Load. Also, Simultaneous Operation Of Wind And Solar System Is Supported By Battery For The Same Load. The Importance Of Single-Stage Converter Systems For SE (PV Arrays And Fuel Cells) Applications Has Been Presented. Several Topologies Were Reviewed, And A Novel Switching Pattern Has Been Proposed Based On The VSI Topology. The Simulation Setup Constructed For The Proposed Switching Pattern Had Promising Results And Verified Its Capability. Therefore, the solution is very attractive for PV/Wind-battery function, by reason of it reduces the alteration steps number, by that developing system's capability and decreasing expenditure, burden, also size of the system.

FUTURE SCOPE

- 1) The losses incurred at the initial working stage of PV can be controlled through optimum modeling of essential parameters.
- 2) Dump Load can be used to dispose excess power
- 3) Transformer can be added to distribute supply variedly to the load
- 4) PID controllers with SVPWM can be used to control current in required circuit.
- 5) A current controller is designed to react to and absorb unanticipated Power disturbances in the utility grid

REFERENCES

- [1] U.S. Department of Energy, "Solar energy grid integration systems-energy storage (SEGIS-ES)," May 2008.
- [2] D. Bundestag, "Gesetz zur Neuregelung des Rechts der erneuerbaren Energien im Strombereich und zur Änderung damit zusammenhängender Vorschriften," Bundesgesetzblatt, 2008.
- [3] H. Konishi, T. Iwato, and M. Kudou, "Development of large-scale power conditioning system in Hokuto mega-solar project," in Proc. Int. Power Electron. Conf., 2010, pp. 1975–1979.
- [4] J. H. Enslin and D. B. Snyman, "Combined low-cost, high efficient inverter, peak power tracker and regulator for PV applications," IEEE Trans. Power Electron., vol. 6, no. 1, pp. 73–82, Jan. 1991.
- [5] H. Ertl, J. W. Kolar, and F. Zach, "A novel multicell dc-ac converter for applications in renewable energy systems," IEEE Trans. Ind. Electron., vol. 49, no. 5, pp. 1048–1057, Oct. 2002.
- [6] C. Zhao, S. D. Round, and J. W. Kolar, "An isolated three-port bidirectional dc/dc converter with decoupled power flow management," IEEE Trans. Power Electron., vol. 23, no. 5, pp. 2443–2453, Sep. 2008.

- [7] M. Bragard, N. Soltau, R. W. De Doncker, and A. Schiemgel, "Design and implementation of a 5 kW photovoltaic system with Li-ion battery and additional dc/dc converter," in *Proc. IEEE Energy Convers. Congr. Expo.*, 2010, pp. 2944–2949.
- [8] W. Li, J. Xiao, Y. Zhao, and X. He, "PWM plus phase angle shift control scheme for combined multiport dc/dc converters," *IEEE Trans. Power Electron.*, vol. 27, no. 3, pp. 1479–1489, Mar. 2012.
- [9] N. Benavidas and P. Chapman, "Power budgeting of a multiple-input buck-boost converter," *IEEE Trans. Power Electron.*, vol. 20, no. 6, pp. 1303–1309, Nov. 2005.
- [10] P. Barrade, S. Delalay, and A. Rufer, "Direct connection of supercapacitors to photovoltaic panels with on-off maximum power point tracking," *IEEE Trans. Sustainable Energy*, vol. 3, no. 2, pp. 283–294, Apr. 2012.
- [11] S. J. Chiang, K. T. Chang, and C. Y. Yen, "Residential photovoltaic energy storage system," *IEEE Trans. Ind. Electron.*, vol. 45, no. 3, pp. 385–394, Jun. 1998.
- [12] Z. Zhao, M. Xu, Q. Chen, J. Lai, and Y. Cho, "Derivation, analysis, and implementation of a boost-buck converter-based high-efficiency PV inverter," *IEEE Trans. Power Electron.*, vol. 27, no. 3, pp. 1304–1313, Mar. 2012.
- [13] C. Ho, H. Breuninger, S. Pettersson, G. Escobar, L. Serpa, and A. Coccia, "Practical design and implementation procedure of an interleaved boost converter using SiC diodes for PV applications," *IEEE Trans. Power Electron.*, vol. 27, no. 6, pp. 2835–2845, Jun. 2012.
- [14] M. Bragard, N. Soltau, R. W. De Doncker, and A. Schiemgel, "Design and implementation of a 5 kW PV system with Li-ion battery and additional dc/dc converter," in *Proc. IEEE Energy Convers. Congr. Expo.*, 2010, pp. 2944–2949.