

**FEASIBILITY & COMPARATIVE STUDY OF ANALYSIS &
DESIGN OF RCC & PSC GIRDER**

Govind.H.Dake¹, Suchita Ramchandra Dhole², Vaibhav.B.Chavan³

¹ Assistant professor, Department Of Civil & Structural Engineering, Shreeyash College Of Engineering And Technology Aurangabad, India

² PG Student, Department Of Civil & Structural Engineering, Shreeyash College Of Engineering And Technology Aurangabad, India

³ Professor and Head, Department Of Civil & Structural Engineering, Shreeyash College Of Engineering And Technology Aurangabad, India

Abstract — This Topic is Concentrated on Bridge ‘Girder’ Component. The Importance of This Paper is to display Basic Economical aspect of Girder With its Span & Type of Design. By study of this paper Designer can choose feasible Design methodology for Girder on primary stage which will impart Economy in Project. The Two main Design methodology of Girder is ‘Reinforced Cement Concrete’ (RCC) & ‘Prestressed Concrete’ (PSC). This Paper deals with both design aspects so result will give idea about which type of Design should be done for Respective Span of girder.

Keywords— RCC Girder, PSC Girder, RCC Vs PSC Girder, RCC Girder Costing, PSC Girder Costing

Received: 30/07/2021 **Accepted:** 17/08/2021 **Published:** 22/08/2021

I. INTRODUCTION

The Infrastructure in India is booming day by day as Development of Nation is largely Depend upon its Infrastructure, The Bridge is Main Component in Infrastructure which contain large amount of cost. It is well known that time required for construction hugely effects on cost of project. In Bridge Construction the type of Girder plays important role in time required for construction such as if Girder is PSC type then it will required more time for stressing work then after Deck slab can be cast. In case of RCC Girder only after Curing time Deck slab can be cast. Also Type of Girder largely depends upon Its Span. This paper will help to choose type of Design methodology on primary stage so that Economical aspect will be also considered with respect to Time.

II. MERITS & DEMERITS OF RCC & PSC GIRDER

Table – I

Merits & Demerits of RCC & PSC Girder

Type of Girder	Merits	Demerits
RCC Girder	1) Speed of Construction is fast.	1) Life Span of RCC girders are less compared to PSC Girder.
	2) DE staging can be done after curing period.	2) For larger Span More steel required results in increase in Cross sectional area.
	3) No extra space required for Stressing work so that width of pier cap can be reduced.	3) Costlier for longer spans.
	4) Feasible in Curve Span.	4) Sagging can't be control in future
PSC Girder	1) Due to Ht Strands steel requirement is less.	1) Time require for construction is more due to prestressing work.
	2) Life Span of PSC girders is more.	2) Space Required at End of girder for stressing which increases width of Pier cap.
	3) For Longer spans PSC Girder is economical.	4) In appropriate Stressing can cause Bursting of Girder.

III. PROBLEM STATEMENT

A Typical Bridge Cross section is taken for Design Calculations having Three No. of supporting Girders as shown in fig.1

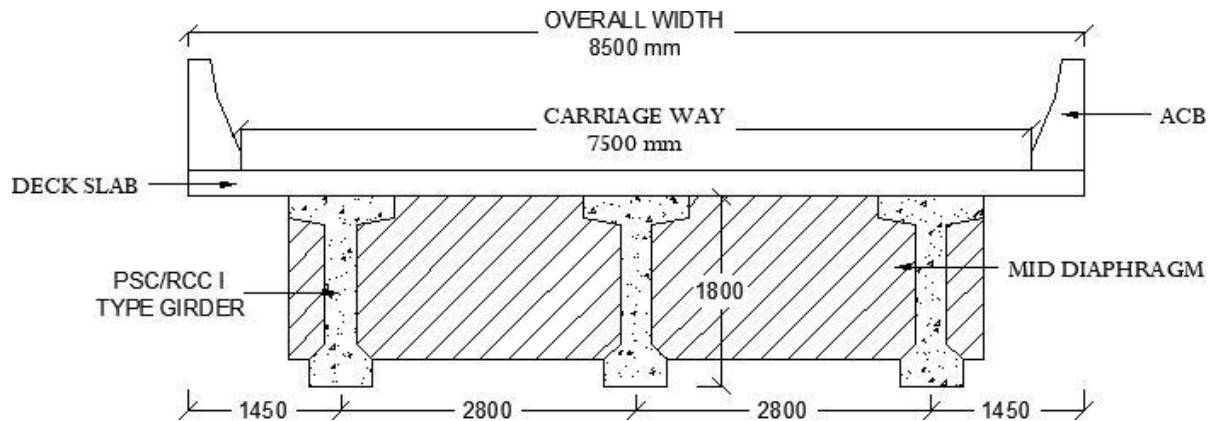

Fig No 1 – Typical cross Section of Bridge at Mid span Location.

A. Load Calculation -

- 1) Dead Load (Self weight) of Girder
- 2) Dead Load of Deck Slab
- 3) Dead Load Of Wearing Coat (SSDL)
- 4) Super Imposed Dead Load (SIDL) – Dead Load of Anti crash barrier.
- 5) Diaphragm Dead Load
- 6) Live Load As per IRC 6 : 2017

As per IRC 6 – 2017 Table No 6A the Loading arrangement On Bridge is as follow:

Condition I - Class 70 R (W) At Minimum Eccentricity

Condition II - Class 70 R (W) On Girder

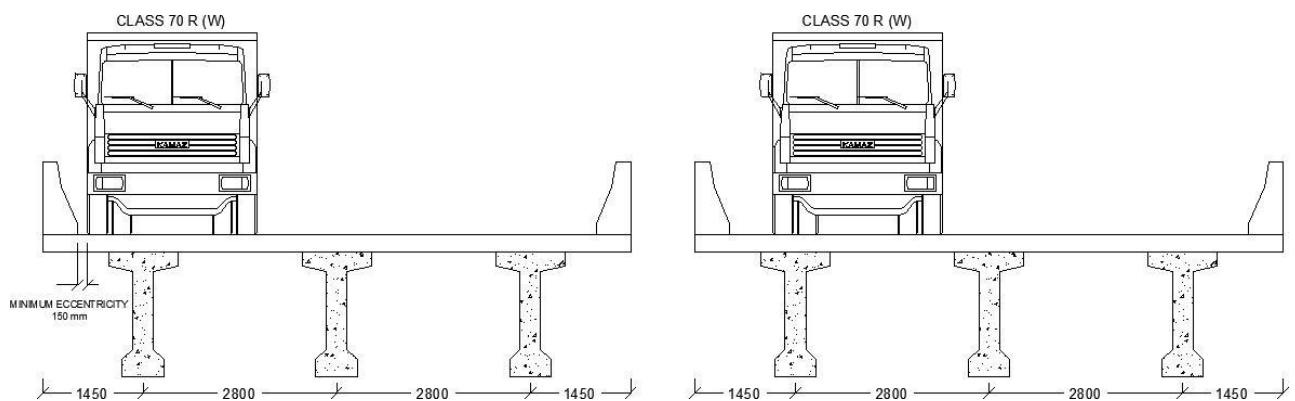

Fig – 2 Class 70 R (W) Loading

Condition III - Class 'A' At Minimum Eccentricity

Condition IV - Class 'A' On Girder

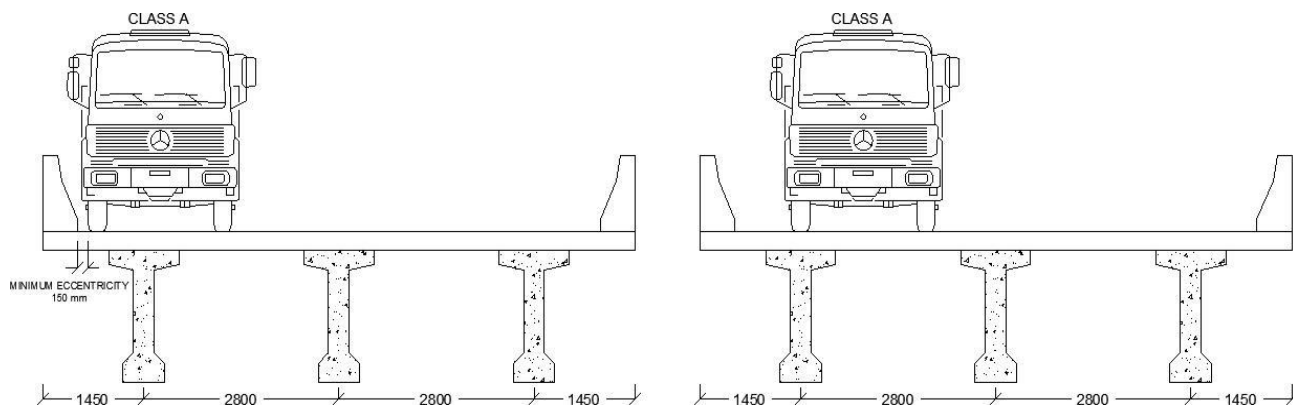

Fig – 3 Class A Loading

Condition V - Class 'A A' At Minimum Eccentricity

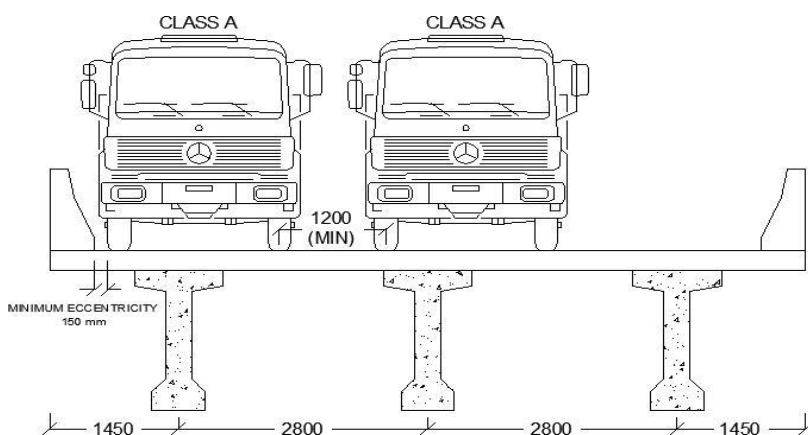

Fig – 4 Class 'A A' Loading

An Individual Girder is Divided into Three Parts along its Length as :

- 1) End Section of Girder
- 2) Slanting (Tapered) Section of Girder
- 3) Mid-section of girder

For Girder Load Analysis Imaginary Sections Along Half-length of Girder is taken as shown in Fig 5

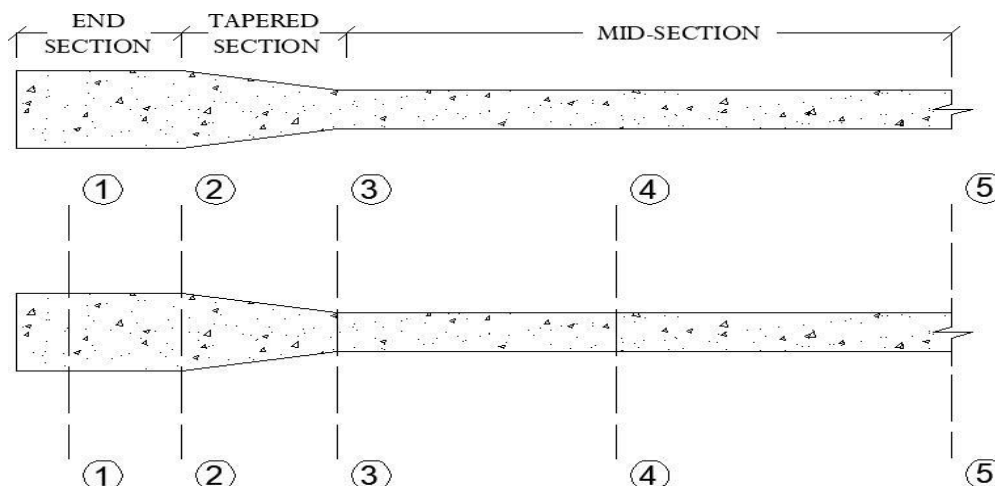

Fig – 5 Girder Plan Showing Section details.

The End Section is provided with more width which imparts stability to girder & also in Case of PSC Girder Because of stressing, The stresses induces in End section is more which require more cross sectional area.

To achieve economy in concrete consumption the cross sectional area is reduced at Mid-section.

B. Load Combination (IRC 6 – 2017 Clause 202.3 Annexure B)

Limit State of Serviceability (SLS)

- I Rare Combination = 1 x DL + 1 x SIDL + 1.2 x SSDL + 1 x LL
- II Frequent Combination = 1 x DL + 1 x SIDL + 1.2 x SSDL + 0.75 x LL
- III Quasi- Permanent Combination = 1 x DL + 1 x SIDL + 1.2 x SSDL

For 30 m Length of Girder the Design Bending Moment is as follow:

Table II
30 m Span Bending Moment Table

Section		Sec. 5 - 5'	Sec. 4 - 4'	Sec. 3 - 3'	Sec. 2 - 2'	Sec. 1 - 1'
Distance		14.500 m	10.875 m	2.175 m	0.675 m	- 0.325 m
ULS	B.M.	1172.45 Tm	1100.94 Tm	327.529 Tm	101.632 Tm	-15.029 Tm
	S.F.	24.55 T	56.96 T	146.35 T	159.26 T	172.65 T
Rare	B.M.	829.842 Tm	779.22 Tm	232.006 Tm	72.2363 Tm	-10.001 Tm
	S.F.	16.36 T	39.53 T	103.21 T	112.51 T	122.25 T
Frequent	B.M.	756.231 Tm	710.236 Tm	211.946 Tm	66.6217 Tm	-7.47018 Tm
	S.F.	12.27 T	33.97 T	93.14 T	102.04 T	111.53 T
Quasi-Permanent.	B.M.	535.398 Tm	503.285 Tm	151.765 Tm	49.7778 Tm	0.12229 Tm
	S.F.	0.00 T	17.30 T	62.92 T	70.64 T	79.36 T

Similarly For Span 20m & 25m Analysis & Design is carried out And From Results Cost can be calculated.

IV. COST CALCULATION

Table – III
RCC Girder Cost calculations

20 m Span								
No	Material	Grade	Rate in Rs	Unit	Quantity	Unit	Quantity	Unit
1	Steel	Fe 500	52.00	Per Kg	1700.00	Kg	88400	Rs
2	Concrete	M 45	4500	m3	17.00	m3	76500	Rs
Total Cost							164900.00	Rs
Cost Per Running Meter							8678.95	Rs/m
25 m Span								
No	Material	Grade	Rate in Rs	Unit	Quantity	Unit	Quantity	Unit
1	Steel	Fe 500	52.00	Per Kg	3500.00	Kg	182000	Rs
2	Concrete	M 45	4500	m3	19.67	m3	88515	Rs
Total Cost							270515.00	Rs
Cost Per Running Meter							11271.46	Rs/m
30 m Span								
No	Material	Grade	Rate in Rs	Unit	Quantity	Unit	Quantity	Unit
1	Steel	Fe 500	52.00	Per Kg	5084.14	Kg	264375	Rs
2	Concrete	M 45	4500	m3	24.59	m3	110636	Rs
Total Cost							375010.82	Rs
Cost Per Running Meter							12931.41	Rs/m

Table – IV

PSC Girder Cost calculations

20 m Span								
No	Material	Grade	Rate in Rs	Unit	Quantity	Unit	Quantity	Unit
1	Steel	Fe 500	52.00	Per Kg	1280.00	Kg	66560	Rs
2	Concrete	M 45	4500	m3	17.00	m3	76500	Rs
3	Ht Strands	Class I	55	Per m	984.00	m	54120	Rs
Total Cost							197180.00	Rs
Cost Per Running Meter							10377.89	Rs/m
25 m Span								
No	Material	Grade	Rate in Rs	Unit	Quantity	Unit	Quantity	Unit
1	Steel	Fe 500	52.00	Per Kg	1350.00	Kg	70200	Rs
2	Concrete	M 45	4500	m3	19.67	m3	88515	Rs
3	Ht Strands	Class I	55	Per m	1200.00	m	66000	Rs
Total Cost							224715.00	Rs
Cost Per Running Meter							9363.13	Rs/m
30 m Span								
No	Material	Grade	Rate in Rs	Unit	Quantity	Unit	Quantity	Unit
1	Steel	Fe 500	52.00	Per Kg	1403.62	Kg	72988	Rs
2	Concrete	M 45	4500	m3	24.59	m3	110636	Rs
3	Ht Strands	Class I	55	Per m	2318.00	m	127490	Rs
Total Cost							311114.20	Rs
Cost Per Running Meter							10728.08	Rs/m

On the Basis of Above cost calculation the graph is plotted on 'x' Axis Span in mm & 'Y' Axis shows Cost of girder in INR per meter length.

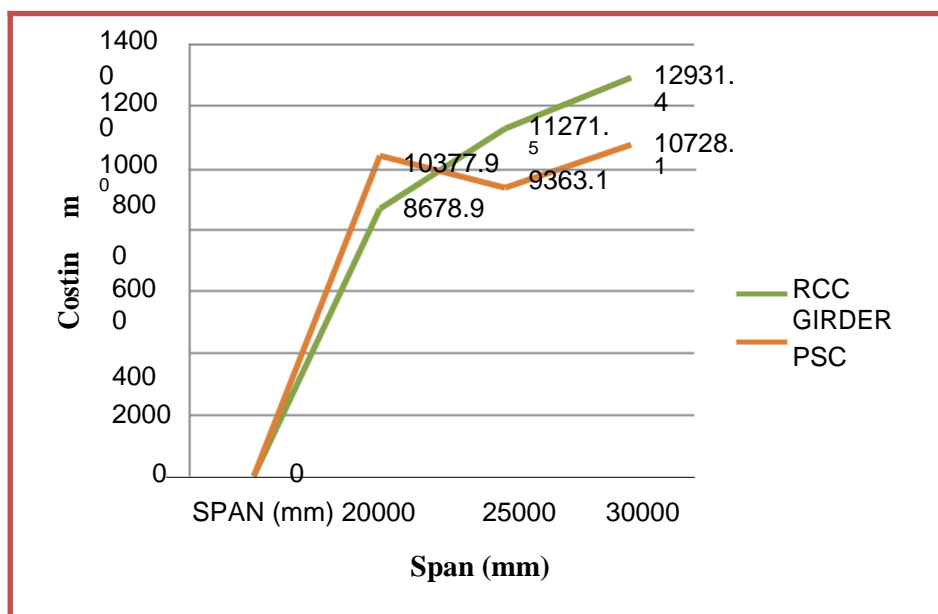

Graph – 1 RCC Vs PSC Girder Costing

V. CONCLUSION

- RCC Girder is 16 % more Economical Compare to PSC Girder for Span of 20 m.
- PSC Girder is 17 % More Economical Compare to RCC Girder for Span of 25 m.
- RCC Girder Design is Economical up to Span of 22 m And Beyond Span 22 m PSC Girder is More Economical.
- In Case of RCC Girders for Larger Spans beyond 25 m Steel requirement is more, which results into increase in cross sectional area which tends to increase in Concrete consumption.

REFERENCE

- [1] Ayush Tiwari & Dr. Sudhir S Bhadouria, U.I.T. Bhopal, M.P., India(2017) "Cost Comparison of RCC Girder and PSC Girder "
- [2] Varun.T.Naik, Yashavantha (2016, IRJET) "Comparative Study of Precast RCC I-Girder Configuration For Various Span Arrangements In A Bridge Super Structure"
- [3] Umang Parekh,Sanket Patel L.J. Institute of Engineering & Technology, Ahmadabad (May 2016) "Comparative Study of PSC. Tee Girder and PSC Box Girder"