

THIN FILM COATINGS effect ON DRILL BIT

¹M.S.KULKARNI, ²NILIMA GOVEKAR

Student, Department of Mechanical, Mandsaur Institute of Technology (MIT)

Professor, Department of Mechanical Engineering, Mandsaur Institute of Technology (MIT)

Abstract

In view of the lack of reliable predictive wear theories, this paper was set up to study, experimentally, the effects of PVD surface coatings namely TiAlN, TiN+TiAlN, AlCrN on carbide twist drill bit by drilling the mild steel as work material. In the case of the TiAlN and AlCrN coated twist drill bit, an improvement in the tribological interaction between the coatings and the workpiece and also increased oxidation resistance resulted in a significant reduction in material transfer at the cutting edge. The above results are discussed in terms of the major flank wear. The use of coatings for cutting tools is nowadays widespread, however, wear mechanisms are not always understood, and a clear relationship between coating's laboratory characterisation and operational machining performance are seldom assessed. The possibility of correlating the laboratory characterisation results with real tools operational performances would be a key issue in reducing development costs of innovative coatings. High oxidation resistant coatings, such as TiAlN, are used extensively in global manufacturing for reducing production costs and improving productivity in such aggressive metal-cutting operations. In this investigation, the performance of uncoated, TiAlN, TiN+TiAlN and TiN+AlCrN coatings was assessed on DIN6357K Carbide twist drill bit used to machine mild steel. As part of the study, the experimental method was used to characterise the performance of the twist drill bit by measuring of the progression of major flank wear. It showed that a multi layer TiN+TiAlN coating and uncoated drill bit failed to outperform TiAlN and AlCrN coated twist drill bit when machining mild steel under aggressive machining conditions.

Keywords: Cathodic Arc Evaporation; Drilling; TiAlN; TiN+AlCrN; Wear, PVD.

1. INTRODUCTION

All manufacturing industry is constantly striving to decrease its cutting costs and increase the quality of the machined parts as the demand for high tolerance manufactured goods is rapidly increasing. The increasing need to boost productivity, to machine more difficult materials and to improve quality in high volume by the manufacturing industry has been the driving force behind the development of cutting tool materials [1].

Cemented carbides are the most popular and most same high production tool materials available today [2]. The productivity enhancement of manufacturing processes is the acceleration of improved cutting tools with respect to the achievement of a superior tribological attainment and wear-resistance [3]. This resulted in developing hard coating for cutting tools; these hard coatings are thin films of one layer to hundreds of layers. These hard coatings have been proven to increase the tool life by slowing down the wear phenomenon of the cutting tools. This increase in tool life allows for less frequent tool changes, therefore increasing the batch sizes that could be manufactured and in turn, not only reducing manufacturing cost, but also reducing the setup time as well as the

setup cost. In addition to increasing the tool life, hard coating deposited on cutting tools allows for improved and more consistent surface roughness of the machined work piece. [4]

The majority of carbide cutting tools in use today employ chemical vapour deposition (CVD) or physical vapour deposition (PVD) hard coatings. The high hardness, wear resistance and chemical stability of these coatings offer proven benefits in terms of tool life and machining performance. The reason PVD is becoming increasingly favourable over CVD is the fact that the coating process occurs under much lower temperature. [5]

1.1 WEAR

Tool failure is said to occur when the tool no longer performs the desired function where as total failure (ultimate failure) is defined as the complete removal of the cutting edge, a condition obtaining when catastrophic failure occurs [6]. Therefore, in machining operations, tools are considered to be worn out and are changed long before total failures to avoid incurring high costs associated with such catastrophic failures. [7] Some of the tool life rejection criteria presented in ISO 3685 is listed below

1. Average flank wear ≥ 0.4 mm
2. Maximum flank wear ≥ 0.6 mm

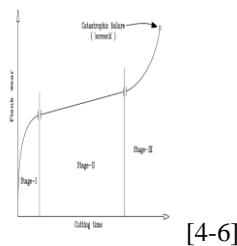

Fig 1 A schematic diagram of a three-stage wear model

2. EXPERIMENTAL PROCEDURE

2.1 Coating Deposition

Coating was carried out using Cathodic Arc Process. Cathodic arc deposition or Arc-PVD is a physical vapour deposition technique in which an electric arc is used to vaporize material from a cathode target. In this process, an arc with a diameter of just a few microns is run over the solid metallic coating material, causing it to evaporate. Because of the high currents and power densities used, the evaporated material is almost totally ionised and forms high-energy plasma. A reactive gas will be supplied through nozzle which will react with the substrate and coating is deposited on the material. The coating was carried out on DIN6537K carbide twist drill bit using three different types of material by cathodic Arc Process. 1) Titanium Nitride (TiN) + Titanium Aluminium Nitride (TiAlN) coating(nano firex) (multi layer) 2) Titanium Aluminium Nitride (TiAlN) coating 3) Aluminium Chromium Nitride (AlCrN)

2.2 CHARACTERIZATION OF TOOL COATINGS

The evaluation of coating characteristics was performed through following tests 1)Surface Roughness 2) Micro hardness Test 3) Semi Electron Microscope(SEM) and Elemental Dispersive X-ray Spectroscopy (EDS) analysis

Surface Roughness: Arithmetic average roughness, Ra test was used to determine the roughness of each coating. Ra is calculated as the integral of the absolute value of roughness profile height over the evaluation length, or the area between the roughness profile and its mean line. Roughness plays an important role in determining how a real object will interact with its environment. Rough surfaces usually wear more quickly and have higher friction coefficients than smooth surfaces.

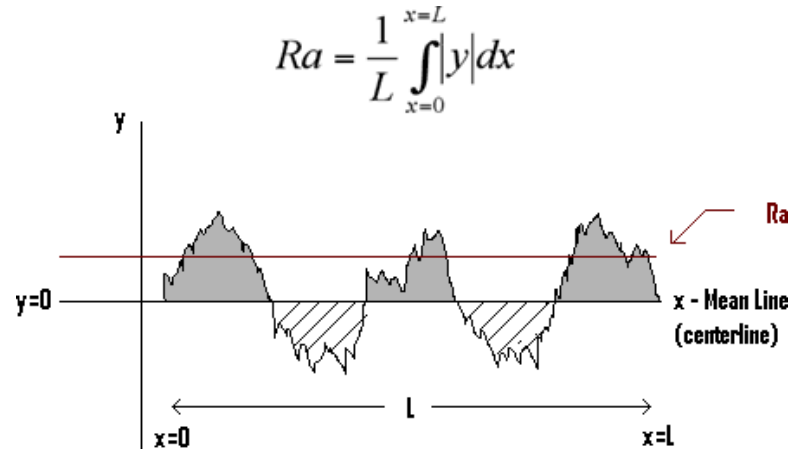

Fig 2 graphical representation of surface roughness

Sl.no.	Coating type	Ra value
1	Tungsten carbide (WC)	0.2356
2	TiAlN	0.2629
3	AlCrN	0.2617
4	TiN+TiAlN	0.2990

Table 1 Ra values of different coatings

Micro Hardness Test: Micro hardness test was conducted to determine the hardness of each coating at HV0.05 scale. This test is conducted to determine the hardness of the uncoated carbide tool and the coated carbide tools. This test is important as hardness changes due to thin film coatings.

Weight of 50gm (hv0.05)	TiAl	TiN+TiAlN	AlCrN
Hardness number	3200	3300	3200
Arithmetic mean of D	0.054mm	0.047mm	0.054mm

Table 2 hardness value of different coating

SEM and EDS Analysis: EDS analysis was carried out to determine the elemental composition of coating and SEM analysis was carried out to study the surface morphology of the coating.

Table 3 elemental composition of different coatings

Major element (at %)	TiN+ TiAlN	TiAlN	AlCrN
Ti	20.01	27.12	-----
Al	22.02	17.76	27.83
Cr	-----	-----	19.34
N	32.53	55.63	53.27
O	12.37	-----	-----
C	12.77	-----	-----

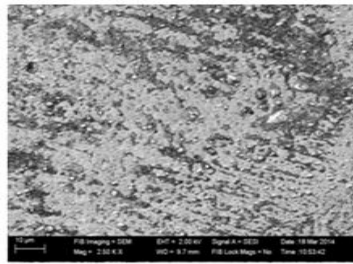

Fig 3 SEM image of TiAlN

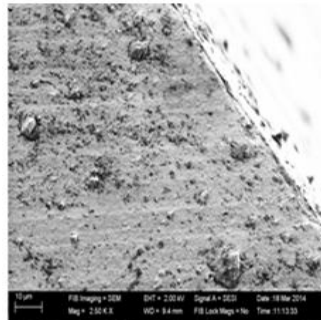

Fig 4 SEM image of AlCrN

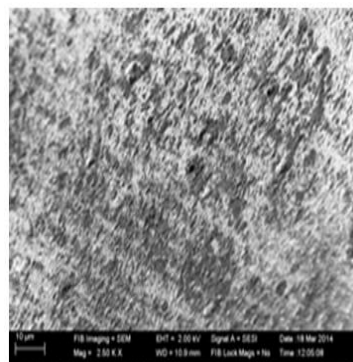

Fig 5 SEM image of TiN+TiAlN

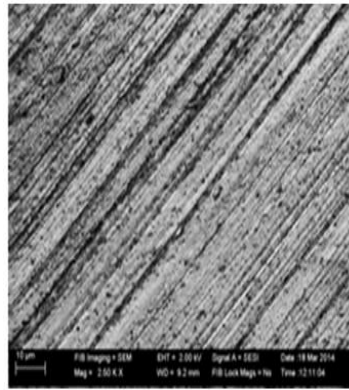

Fig 6 SEM image of uncoated carbide

From the SEM images of TiAlN it has been observed that there are some amount particles like structure present on the surface. It is because of presence of the aluminium with titanium which forms the uneven surface and this increases the hardness of coating and the oxidation resistance of the coating will also be increased.

From the SEM images of AlCrN (fig 4) it has been observed that there are some amount particles like structure present on the surface. It is because of presence of the aluminium with titanium which forms the uneven surface and this increases the hardness of coating and the oxidation resistance of the coating will also be increased. Al based coatings provide chemical inertness, hardness and good wear resistance due to the formation of Al_2O_3 layer on the tool surface at high temperatures.

From the SEM images of TiN+TiAlN (fig 5) it has been observed that the coating is not much even or smooth surface compared to TiAlN. In this type coating TiN helps in reducing propagation of cracks. TiN and TiAlN films starts to oxidize at temperatures of $550^{\circ}C$ and $800^{\circ}C$. The SEM images of uncoated carbide shown in fig (6) which has the polished line surface

2.3. Cutting tool testing

Machining was performed Using vertical machining centre. The drill bit is selected according to the DIN6535K standards the design of the twist drill bit is shown below fig (7). The drill bit material is commercially available tungsten based cemented carbide will be used. The specification of drill given in table (1). The point angle and flute angle of drill is 140° and 35° and the drill point consists of two facets.

Fig 7 drill bit design

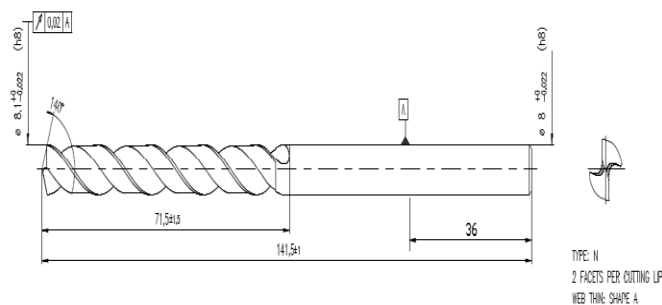

Nominal dia (mm)	Shank dia(mm)	Flute length	Overall length
8mm	8.1mm	71.5mm	141.5mm

Table 4 specification of drill bit

2.4 Coating conditions

	TiAlN	TiN+TiAlN	AlCrN
Identifying Colour	Black violet	Red violet	Grey blue
Thickness	1.5-4microns	1.5-4microns	1.5-4microns
Coating temp ⁰	500 ⁰ c	500 ⁰ c	500 ⁰ c
Layer structure	Monolayer	Multilayer	Monolayer
Thermal stability	<800 ⁰ c	<800 ⁰ c	<1100 ⁰ c

Table 5 coating conditions for various coatings

Workpiece material used for machining operation is mild steel. A 200*100*50 mm sized block was used for the machining operation. The depth of hole is 50mm through hole (plunging type drilling operation) The Feed, Speed and Depth of cut was kept constant for all the four drill bits. The performance of drill bits was characterised by measuring the progression of flank wear lands using Vision Measuring Machine(VMM) and optical microscope.

3.RESULTS AND DISCUSSION

The wear patterns observed are shown in Figs .After every 30 holes the performance of the drill bits and the wear patterns were evaluated. All PVD coated drill bits showed negligible material transfer after the 30 holes drilling where the uncoated drill bit shows the sudden wear propagation at the cutting edge . In the case of the TiN+TiAlN coated drill bit, the resistance to transfer of work piece material after the 30 holes very quickly diminished such that after 60 holes there was significant material transfer on the cutting flank. This rapid onset of material transfer led to complete cutting edge wear which in turn resulted in catastrophic failure and without satisfactory performance in this regard, all drills will rapidly become ineffective due to clogging up the hole. The performance of PVD coated drill bits and uncoated drill bit is evaluated and the pattern of major flank wear was examined using optical microscope.

A more accurate representation of the wear of these coated drill bits in the intermediate Stage II wear region is established after a tool life of 80 holes as shown in Figs.(8-11) . The size of the outer corner wear land has increased in addition to an increase in the extent of work piece material transfer on the cutting edge. The drill bit breaks at the 73rd hole. In contrast, the TiAlN and AlCrN coated drill bits after drilling the 80 holes also showed only a slight increase in the size of the cutting edge wear lands. The wear land and material transfer continued to increase at a constant rate throughout Stage II until the entire cutting edge was covered in material transfer. At this point, the rate of wear increased rapidly as the wear mode switched to Stage III prior to

catastrophic failure. The onset of Stage III wear at the outer corner corresponded to the loss of a cutting edge in all cases.

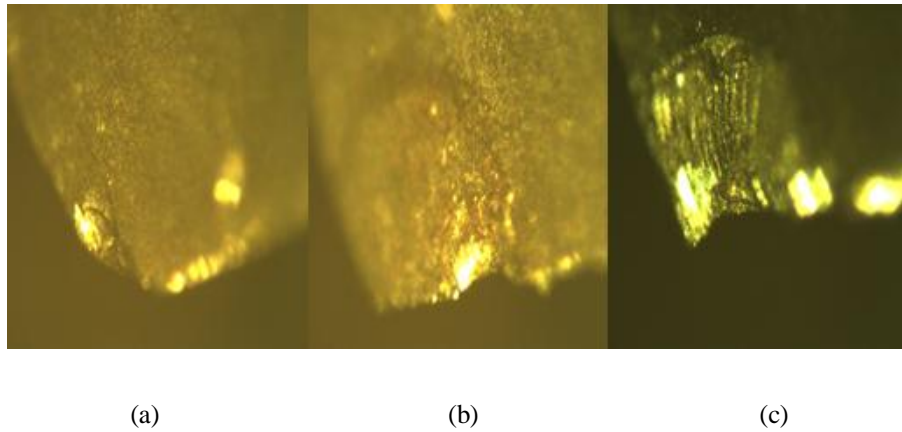

Fig. 8 Optical microscope images of flank wear lands of TiAlN coated carbide drill bit (a) Stage I wear mode (after 30 holes), (b) Stage II wear mode (after 60 holes) and (c) Stage III wear mode (after 90 holes)

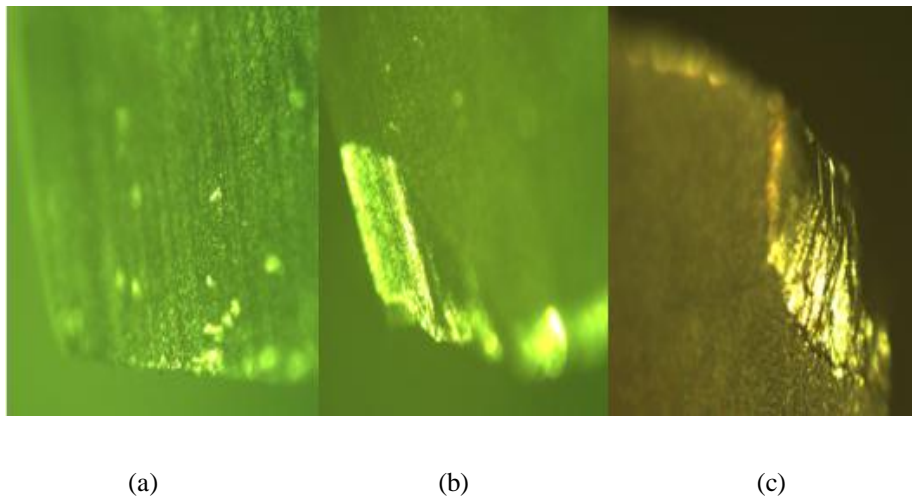

Fig. 9 Optical microscope images of flank wear lands of uncoated carbide drill bit (a) before machining (b) after 30 holes and (c) after 43 holes

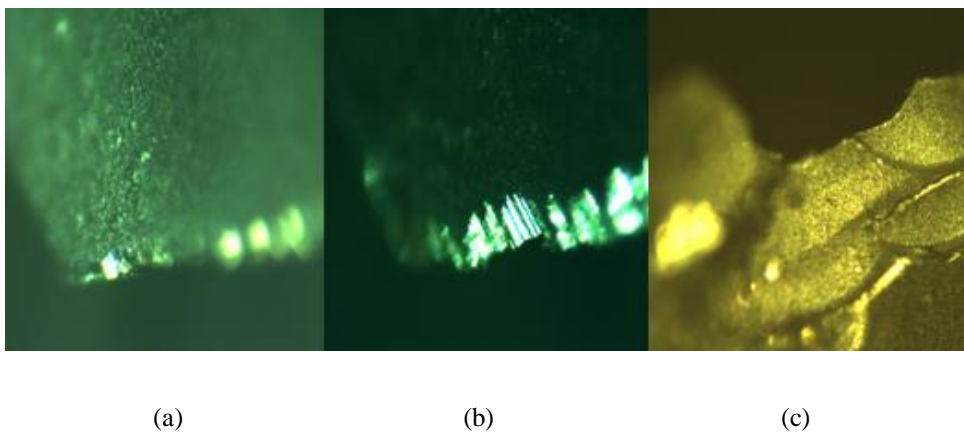

Fig. 10 Optical microscope images of flank wear lands of TiN+TiAlN coated carbide drill bit (a) after 30 holes (b) after 60 holes and (c) after catastrophic breakdown of tool at the 67th hole.

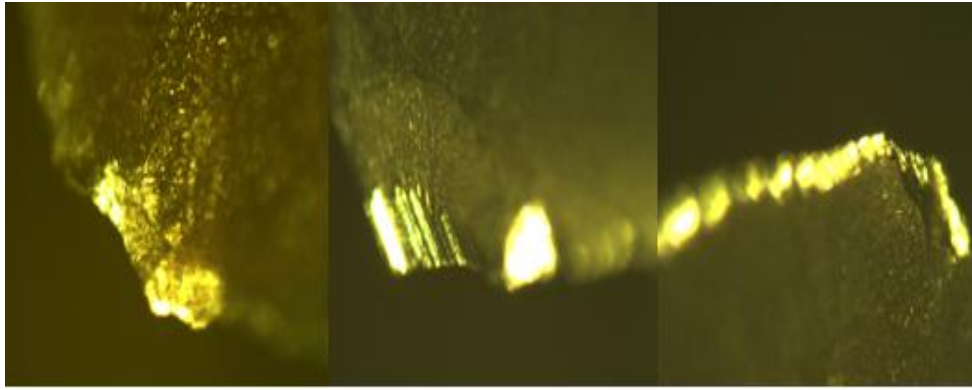

Fig. 11 Optical microscope images of flank wear lands of AlCrN coated carbide drill bit (a) after 30 holes (b) after 60 holes and (c) after 90 hole.

The figure 12 shows the comparison of flank wear of all three coated twist drill bits and one uncoated twist drill bit from following graph we can make out that the TiAlN and AlCrN coated tools well performed from these two coated tools 98 and 116 holes are drilled respectively where as the Nano firex coated and uncoated tools are drilled only 72 and 53 holes respectively. All PVD coated drill bits well performed compared to uncoated tool. From fig 6.9 gives the clear information about the tool flank wear as number of hole drilled increases the flank wear also increases. AlCrN coated drill bit gives the best results compare to all other tools.

The flank wear on drill bits initially occurs because of abrasion, as the wear process progresses the temperature increases causing diffusion and oxidation of coating occurs this reduces the wear rate and this happens usually at the second stage. Once the coating is completely removed the wear rate increases rapidly leading to catastrophic failure before this stage the tools are usually removed and taken for rework.

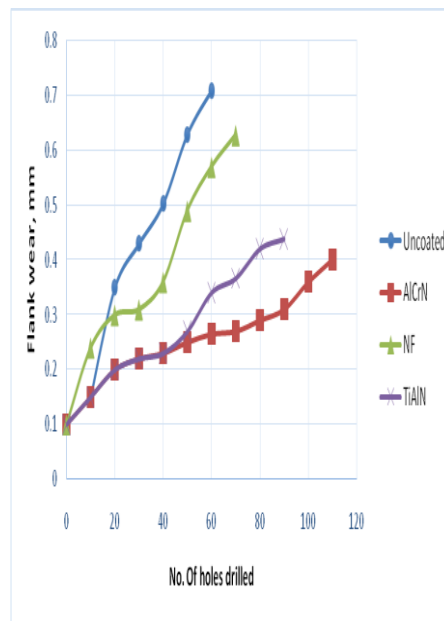

Figure 12: Flank Wear Comparison of all the three coatings and one uncoated tool

4. CONCLUDING REMARKS

As part of the study, measurement of the cutting edge flank wear was carried out. The study showed that the TiAlN and AlCrN coated drills outperformed the uncoated drill bit and TiN+TiAlN coated drill bit. In the present investigation, the machining performance of different PVD coated drill bits were compared when machining mild steel. The coatings were deposited using a multi-source cathodic arc system and included uncoated carbide, TiN+TiAlN, TiAlN and AlCrN coatings. Notwithstanding the initial resistance to material transfer by the TiN+TiAlN coated drill bit and uncoated drill bit after a tool life of 30 and 60 holes they showed a rapid onset of material transfer over the entire cutting edge. The rapid change in the tribological interaction between the tool and the workpiece is thought to be a result of coating oxidation which resulted from the high temperatures and friction generated at the cutting edge. It is evident from the present results that the material transfer via adhesive wear is the key mechanism which dominated the tool failure.

The high oxidation resistance and improved tribological interaction of the TiAlN and AlCrN based coatings made these coatings effective at resisting material transfer and improving cutting tool performance under the aggressive machining conditions.

References

- [1] I.J. Smith, D. Gillibrand, J.S. Brooks, W.-D. Münz, Dry cutting performance of HSS twist drills coated with improved TiAlN, *Surf. Coat. Technol.* 90 (1997) 164–171.
- [2] D. McIntyre, J.E. Greene, G. Håkansson, J.-E. Sundgren, W.-D. Münz, Oxidation of metastable single-phase polycrystalline Ti_{0.5}Al_{0.5}N films—kinetics and mechanisms, *J. Appl. Phys.* 67 (3) (1990) 1542–1553.
- [3] L.A. Donohue, I.J. Smith, W.-D. Münz, I. Petrov, J.E. Greene, Microstructure and oxidation-resistance of Ti_{1-x-y-z}Al_xCr_yY_zN layers grown by combined steered-arc/unbalanced-magnetron-sputter deposition, *Surf. Coat. Technol.* 94–95 (1997) 226–231.
- [4] L. Hultman, Thermal stability of nitride thin films, *Vacuum* 57 (2000) 1–30.
- [5] D.-Y. Wang, Y.-W. Li, C.-L. Chang, W.-Y. Ho, Deposition of high quality (Ti, Al)N hard coatings by vacuum arc evaporation process, *Surf. Coat. Technol.* 114 (1999) 109–113.
- [6] H.K. Tönshoff, A. Mohlfeld, PVD-coatings for wear protection in dry cutting operations, *Surf. Coat. Technol.* 93 (1997) 88–92.
- [7] H.K. Tönshoff, A. Mohlfeld, T. Leyendecker, H.G. Fuß, G. Erkens, R. Wenke, T. Cselle, M. Schwenck, Wear mechanisms of (Ti_{1-x}Al_x)N coatings in dry drilling, *Surf. Coat. Technol.* 94–95 (1997) 603–609.
- [8] S. Kalidas, R.E. DeVor, S.G. Kapoor, Experimental investigation of the effect of drill coatings on hole quality under dry and wet drilling conditions, *Surf. Coat. Technol.* 148 (2001) 117–128.
- [9] J.S. Kim, G.J. Kim, M.C. Kang, J.W. Kim, K.H. Kim, Cutting performance of Ti–Al–Si–N-coated tool by a hybrid-coating system for high-hardened materials, *Surf. Coat. Technol.* 193 (2005) 249
- [10] Konstantinos-Dionysios Bouzakis, Nikolaos Michailidis, Georgios Skordaris Emmanouil Bouzakis, Dirk Biermann, Rachid M'Saoubi. Cutting with coated tools: Coating technologies,

characterization methods and performance optimization CIRP Annals - Manufacturing Technology 61 (2012) 703–723

- [11] S.G. Harris, E.D. Doyle, A.C. Vlasveld, J. Audy, D.Quick. A study of the wear mechanisms of $Ti_{1-x}Al_xN$ and $Ti_{1-x-y}Al_xCryN$ coated high-speed steel twist drills under dry machining conditions Wear 254 (2003) 723–734
- [12] W.-D. Münz, Titanium aluminium nitride films: a new alternative to TiN coatings, J. Vac. Sci. Technol. A 4 (1986) 2717.
- [13] Mouzakis K-D, Gearardis S, Katikirtzoglou G, Makrimallakis S, Bouzakis A, Cremer R, Fuss H-G Application of Coated Tools with Rounded Cutting Edges After the Film Deposition. CIRP Annals – Manufacturing Technology 58(1):61–64, 2009
- [14] Aouzazkis K-M, Papaspa M, Skoasrdxaris G, Boasuazakis E, Gzeraardis S Relation of the PVD Strength and Resistance at Elevated Temperatures. Surface Technology 205(5):1481–1485, 2010.
- [15] AengülManışman, Alami J, Persson, Bouzakis E, Skordaris G, Makrimallakis S, Tsouknidas A, Katirtzoglou G, Gerardis S Effect PVD Wet Micro-blasting by different Al_2O_3 Grain Sizes on the Behaviour of Coated Tools. Surface Technology 205:S128–S132, 2011.
- [16] Luzadakis K-D, Skosrdaris G, Gerafrdis S, Katirtzsoglou G, Makrimaffllakis S, Pappfa M, Bsolz S, Koselker W The Effect of Pre-treatments and HPPMS-deposited layers' Materials on the Performance of Coated Cemented Carbide turning inserts. CIRP Annals – Manufacturing Technology 59(1):73–76, 2010
- [17] Bouzaksdis K-M, Makrimiddallakis S, Katirtzogs lou G, Skordadris G, Gerardis S, Boduzakis E, Leyendsecker T, Bsolz S, Koelkder W Adaption of Cr/CrN-interlayer to Cemented Carbide Substrates' Roughness for the Adhesion of HPPMS PVD Films and the Performance. Surface and Coatings Technology 205(5):1564–1570, 2010
- [18] Mdouaadzakis Kadada-D, Batsisolas M, Malliarsis G, Papadapa M, Bouzaadkis E, Skoraddaris G Methods for Characterizing Coating Properties at Elevated Temperatures. Key Engineering Materials 438:107–114, 2010