

## **SOLAR POWERED LED STREET LIGHT WITH AUTO INTENSITY CONTROL**

T.RAJASEKHAR<sup>1</sup>, Dr. K. PRAHLADA RAO<sup>2</sup>

<sup>1</sup>P.G Scholar, JNTUA College of Engineering, Ananthapuramu, A.P.

<sup>2</sup>Professor & Principal JNTUACEA, Ananthapuramu, A.P.

### **ABSTRACT:**

*The System is designed for LED based street lights with an auto intensity control that uses solar power from photovoltaic cells. Photovoltaic panels are used for charging batteries by converting the sunlight into electricity. It is interfaced with LDR for precise switching operation. The Intensity of street lights is required to be kept high during the peak hours. As the traffic on the roads tends to decrease slowly in late nights, the intensity can be reduced progressively till morning to save energy. Thus, the street lights switch ON at the dusk and then switch OFF at the dawn automatically. The process repeats every day. Light Emitting Diode (LED) can replace the High Intensity Discharge (HID) lamps where intensity control is possible by Pulse Width Modulation. A programmable Microcontroller Atmega328P of Arduino is engaged to provide different intensities at the different times of night using PWM technique for saving the energy.*

**Keywords:** Solar panel, Battery, Arduino board, Atmega328P microcontroller, LDR (Light dependent Resistor), LED (Light Emitting Diode).

### **1. INTRODUCTION**

The main consideration in the present field technologies are Automation, Power consumption and cost effectiveness. Providing street lighting is one of the most important and expensive responsibilities of a city. Energy efficient technologies and design mechanism can reduce cost of the street lighting drastically. There are various numbers of control strategy and methods in controlling the street light system to ensure that it consumes less energy and is efficient in terms of money and usage. The main objective of this paper is to provide a better solution to minimize the electrical wastage in operating street lights, in this electronic era human restless. Manual control is prone to errors and leads to energy wastages and manually dimming during mid night is impracticable. A rapid advancement in embedded systems had paved path for the virtual mechanisms based on microcontrollers. This paper presents solar powered LED street light with auto intensity control which provides different intensities at different times of night using pulse width modulation technique. The system consists of light dependent resistor(LDR) which is also known as photo resistor made of cadmium sulfide is used for precise switching operation and an Atmega328P microcontroller which is programmed using Arduino programming language to act as a pulse width modulator. The program can be rewritable according to the requirements needed.

### **2. LITERATURE REVIEW**

**GongSiliang** describes an automatic streetlight system based on LDR sensor. The system can be set to run in automatic mode, which switch on at the sunset and switch off at the sunrise automatically. This can be possible with the help of LDR (Light Dependent Resistor).

**Gustavo** describes LED street lighting system. The use of LED's is being considered promising solution to modern street lighting systems, due to their longer life time and higher luminous efficiency when compared with high intensity discharge lamps.

**Radha Priyasree** explains a system to reduce the power consumption of streetlights by avoiding inefficient lighting which wastes significant financial resources each year. This is done by dimming the lights during less traffic hours. For this purpose PIR sensor is used which detects any movement. This initiative will help the government to save this energy and meet the domestic and industrial needs.

### 3. BLOCK DIAGRAM

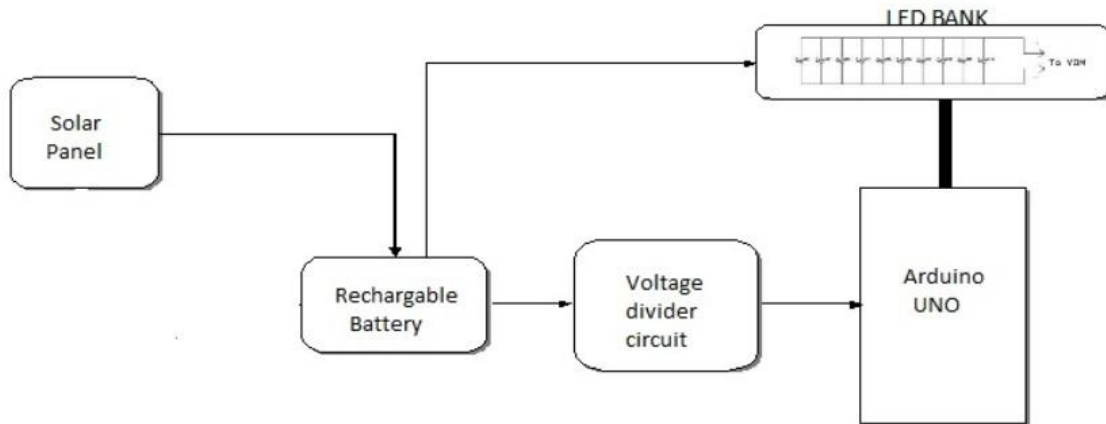

Fig 1. Block Diagram

#### Explanations of Each Block:

**Solar Panel:** A solar panel is a collection of solar cells. The solar panel converts the solar energy into electrical energy. Output of the solar panel is its power which is measured in terms of Watts or Kilo watts. Solar power uses multiple reflectors to collect more sun's thermal energy. Thermal energy collected through the day to perform different operations. Performance of the solar panel depends on a number of factors like climate, conditions of the sky, orientation of the panel, intensity and duration of sunlight and its wiring connections.

**Rechargeable Battery:** A rechargeable battery is a type of electrical battery which can be charged, discharged into a load, and recharged many times, while a non-rechargeable or primary battery is supplied fully charged, and discarded once discharged. Several different combinations of electrode materials and electrolytes are used, including lead-acid, nickel cadmium (Ni-Cd), nickel metal hydride (Ni-MH), lithium ion (Li-ion), and lithium ion polymer (Li-ion polymer).

**Voltage Divider circuit:** A voltage divider is a simple circuit which turns a large voltage into a smaller one. Using just two series resistors and an input voltage, we can create an output voltage that is a fraction of the input. Voltage dividers are one of the most fundamental circuits in electronics equation of circuit.

**Arduino UNO:** Micro-controller will control the intensity of light at different time slots. Micro controller circuit will generate PWM waves to provide different intensities. This system provide sets of digital and analog I/O pins that can be interfaced to the street light circuit. Operating voltage of Arduino UNO is 5v so that we will convert 12v from Battery to 5v.

**LDR:** The theoretical concept of the light sensor lies behind, which is used in this circuit as a darkness detector. The LDR is a resistor as shown in Fig. 2, and its resistance varies according to the amount of light falling on its surface. When the LDR detects light its resistance will get decreased, thus if it detects darkness its resistance will increase.

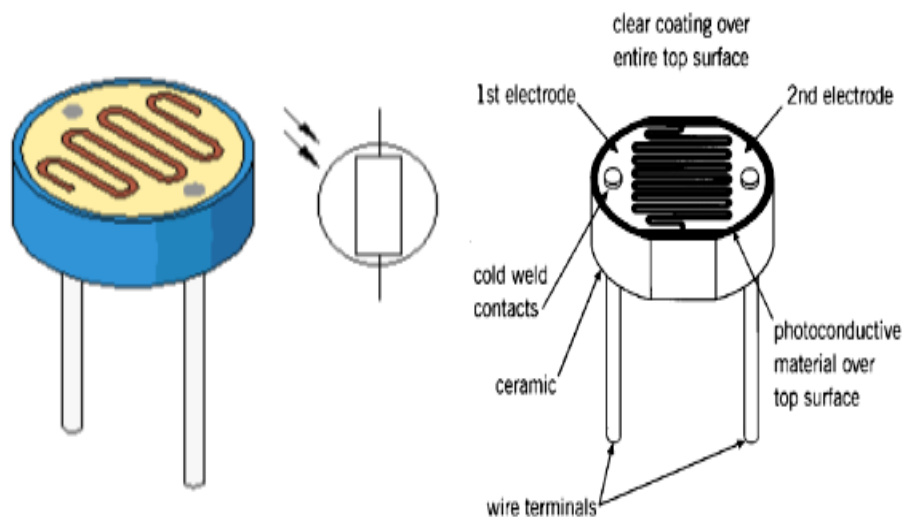

Fig 2. Light Dependent Resistor

#### 4. EXPERIMENTAL SETUP

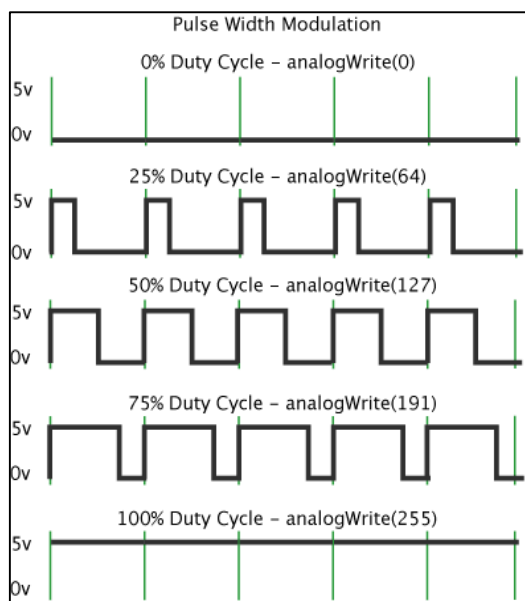

Fig 3. Experimental Setup

#### 5. WORKING

The experimental setup involves the following working principle. The solar panels convert the sun light into electrical energy. This obtained electrical energy during the day time is stored in the rechargeable battery and used during the night time. The solar street light draws the power from the battery. The LDR is used for precise switching operation of street light at the dusk and dawn. Light dependent resistor makes the street light switch on during sunset and switch off during the sunrise automatically. A programmable Microcontroller Atmega328P of Arduino is engaged to provide different intensities at the different times of night using PWM technique for saving the energy.

#### 6. CALCULATIONS



The green lines represent a regular time period. This duration or period is the inverse of the PWM frequency. In other words, with Arduino PWM frequency at about 500Hz, the green lines would measure 2 milliseconds each. A call to analogWrite () is on a scale of 0 - 255, such that analogWrite (255) requests a 100% duty cycle (always on), and analogWrite (127) is a 50% duty cycle (on half the time).

**Timings with Intensity Ratio:**

<b>Time</b>	<b>Intensity</b>
06:00pm - 09:00pm	100% - 75%
09:00pm – 12:00am	75% - 50%
12:00am – 03:00am	50% - 25%
03:00am – 06:00am	25% - 0%

**Advantages:**

- Solar street lights are independent of the utility grid. Hence, the operation costs are minimized.
- Solar street lights require much less maintenance compared to conventional street lights.
- Since external wires are eliminated, risk of accidents is minimized.
- This is a non-polluting source of electricity.
- Separate parts of solar system can be easily carried to the remote areas.

**Disadvantages:**

- Initial investment is higher compared to conventional street lights.
- Risk of theft is higher as equipment costs are comparatively higher.
- Snow or dust, combined with moisture can accumulate on PV panels and reduce or even stop energy production.
- Rechargeable batteries will need to be replaced several times over the lifetime of the street light.
- Non-availability of sunlight during rainy and winter seasons is a problem.

**7. CONCLUSION**

The system ‘SOLAR POWERED LED STREET LIGHT WITH AUTO INTENSITY CONTROL’ is a cost effective, practical, eco-friendly and the safest way to save energy. It clearly tackles the two problems that world is facing today, saving of energy and also disposal of incandescent lamps, very efficiently. It provides different intensities at different times of night. With this energy can be saved to some extent. According to statistical data it saves more than 40 % of electrical energy that is now consumed by the basic solar street light. So throughout the world if this concept is used it will eliminate the energy crisis to a larger extent.

**8. REFERENCES**

- [1]. Dr. D. Asha Devi, Ajay Kumar .Y.L, “Design and Implementation of CPLD based Solar Power Saving System for Street Lights and Automatic Traffic Controller”, International Journal of Scientific and Research Publications, Volume 2, Issue 11, November 2012 1 ISSN 2250-3153
- [2]. K.Y.Rajput<sup>1</sup>, Gargeyee Khatav<sup>2</sup>, Monica Pujari<sup>3</sup>, Priyanka Yadav, “Intelligent Street Lighting System Using Gsm,” International Journal of Engineering Science Invention, Vol.2, Issue 3, pp.60-69, March. 2013.
- [3]. Kapse Sagar Sudhakar<sup>1</sup> , Abhale Amol Anil<sup>2</sup> , Kudake chetan Ashok<sup>3</sup> , Shirsath Shravan Bhaskar, “Automatic Street Light Control System”, International Journal of Emerging Technology and Advanced Engineering, Vol. 3, Issue 5, pp. 188-189, May 2013.
- [4]. Sani, H.NYahya, M. Momoh, I.G. Saidu and D.O.Akpootu, “Design and Construction of Microcontroller Based Charge Controller for Photovoltaic Application”, e-ISSN: 2278 1676,p-ISSN: 2320-3331, Volume 9, Issue 1 Ver. I Jan.2014.
- [5]. Archana M, Mahalahshmi R, “E – Street: LED Powered Intelligent Street Lighting System with Automatic Brightness Adjustment Based On Climatic Conditions and Vehicle Movements”, International Journal of Advanced Research in Electrical, Electronics and Instrumentation Engineering, Vol. 3, Special Issue 2, pp. 60-67, April 2014.
- [6]. Dheeraj sharma, “A Sensor-Less and Energy Efficient Street Light Control System,” International Journal of Advanced Research in Electrical,Electronics and Instrumentation Engineering, Vol. 4, Issue 3, pp. 1805-1812, March 2015.
- [7]. Abdul Latif , Saleem, Raja Sagar R, Sachin Datta N S, Sachin H S, Usha M S, “Street Light Monitoring and Control System”, International Journal of Engineering and Techniques, Vol. 1, Issue2, pp 68-71, Mar – Apr 2015.